



MAXPRO.JP

JAPAN Aluminium

ĐĂNG CẤP THƯƠNG HIỆU NHÔM NHẬT BẢN

HỆ R55

R55

BẢN VẼ LẮP GHÉP |

CỬA SỐ MỞ QUAY |

1 CÁNH

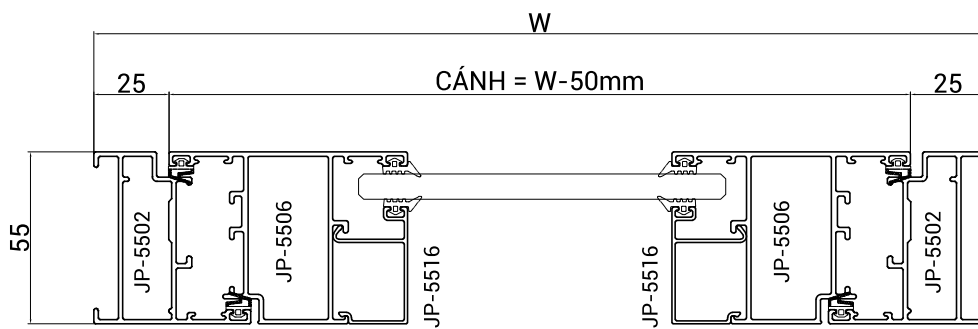
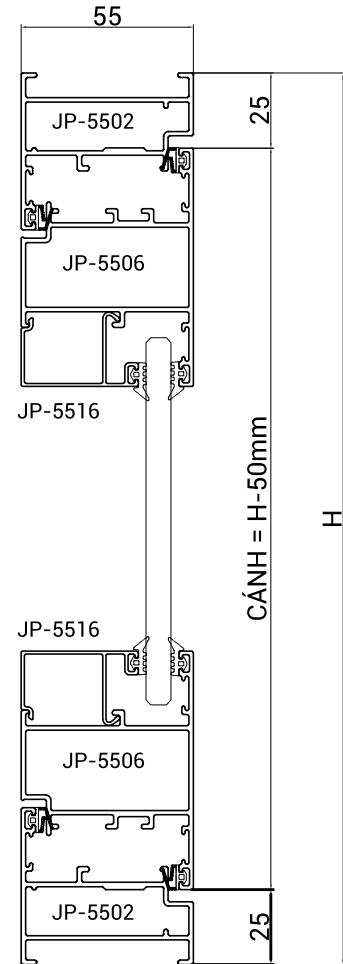
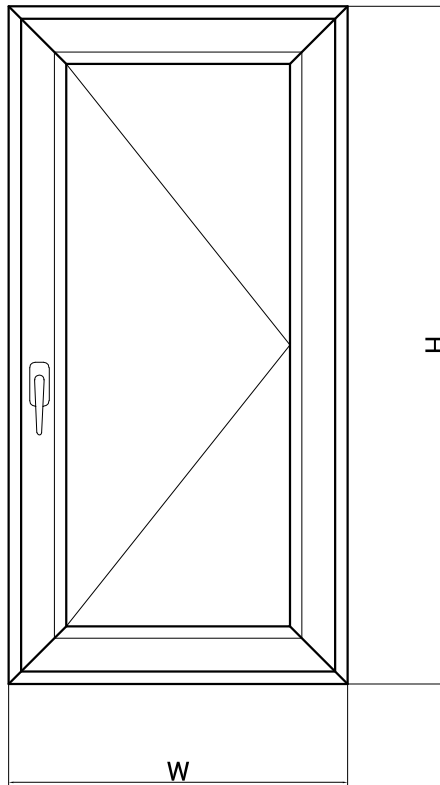

R55

BẢN VẼ LẮP GHÉP |

CỬA SỐ MỞ QUAY |

2 CÁNH

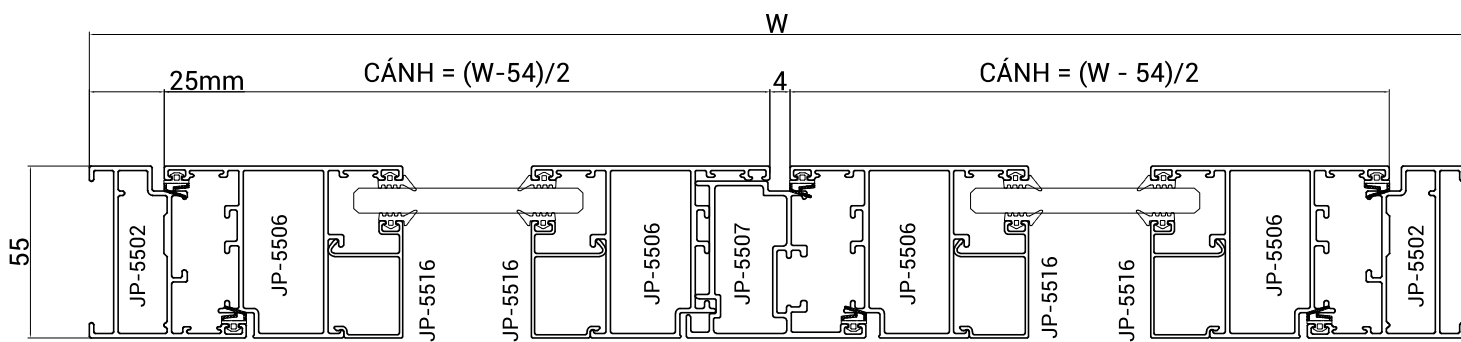
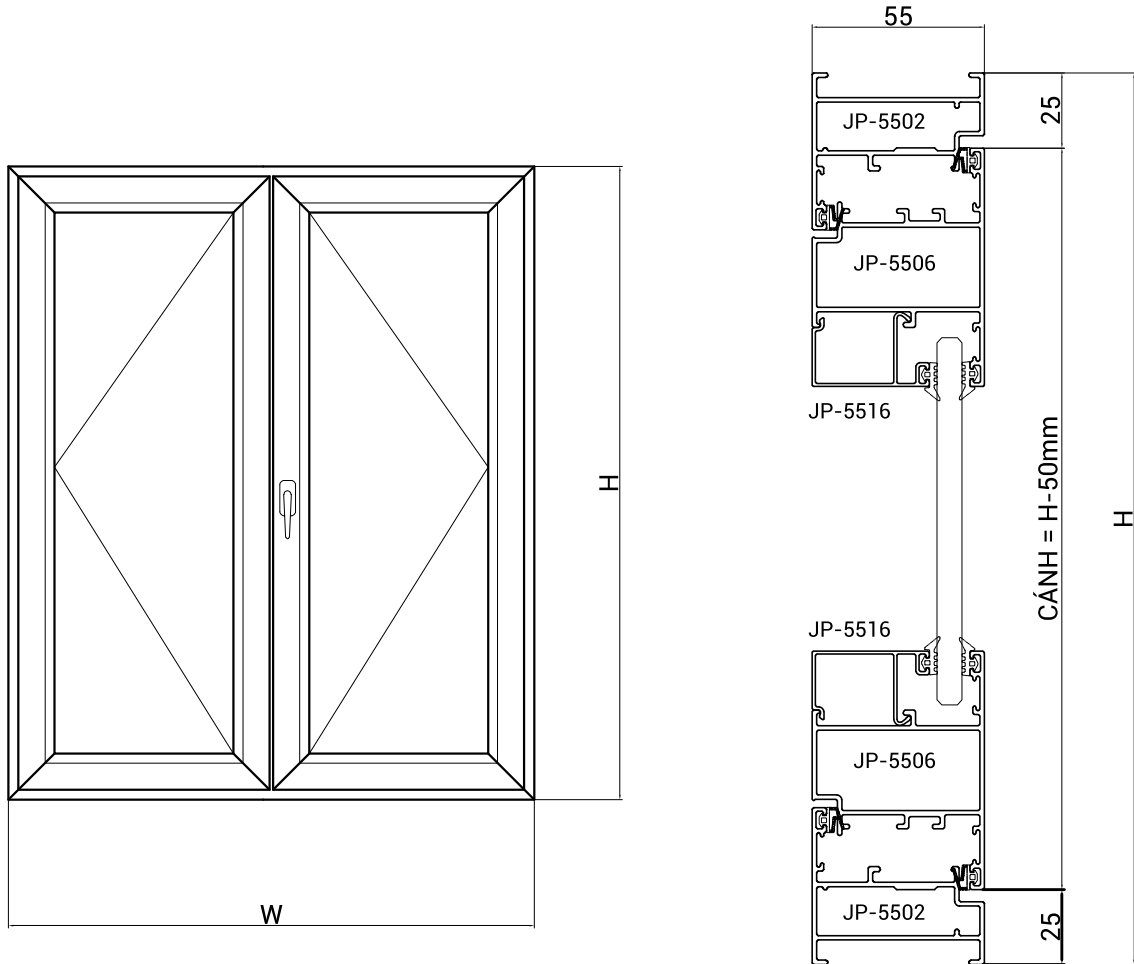

R55

BẢN VẼ LẮP GHÉP |

CỬA SỐ MỞ QUAY |

4 CÁNH

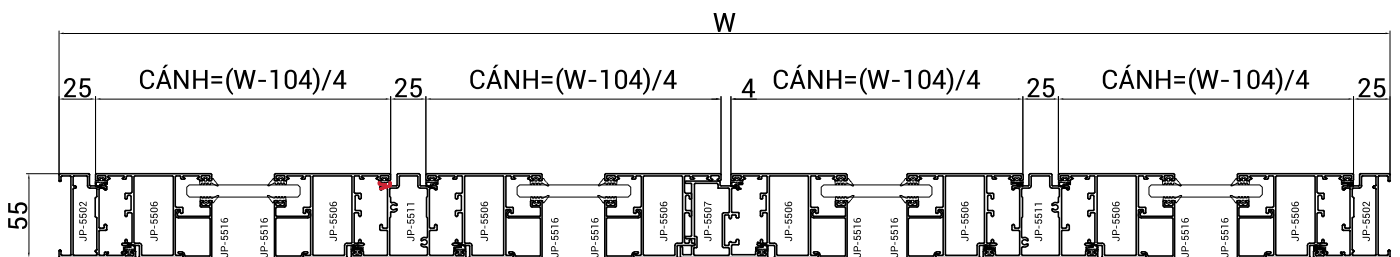
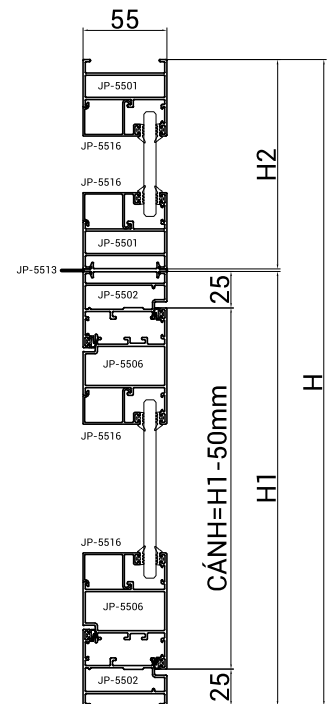
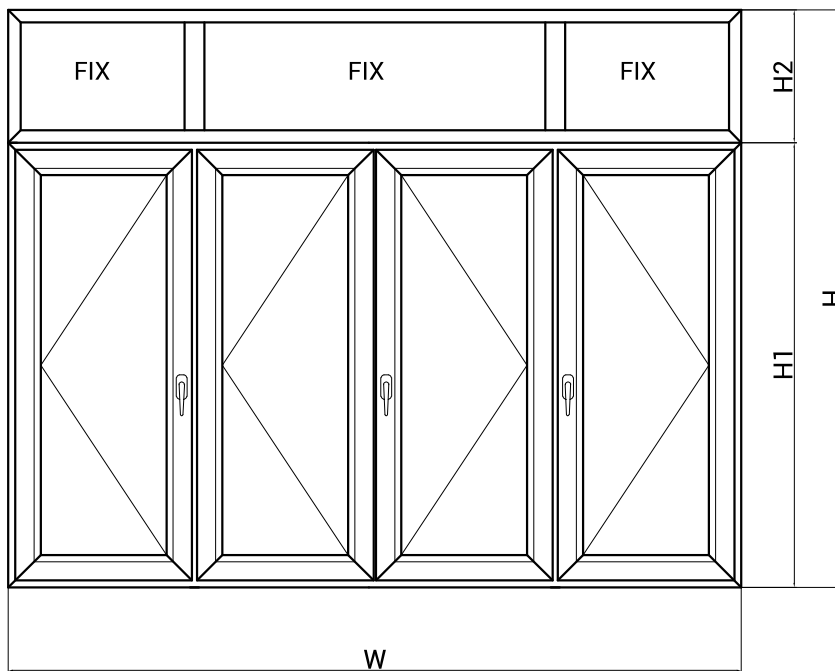

R55

BẢN VẼ LẮP GHÉP |

CỬA ĐI MỞ QUAY |

1 CÁNH

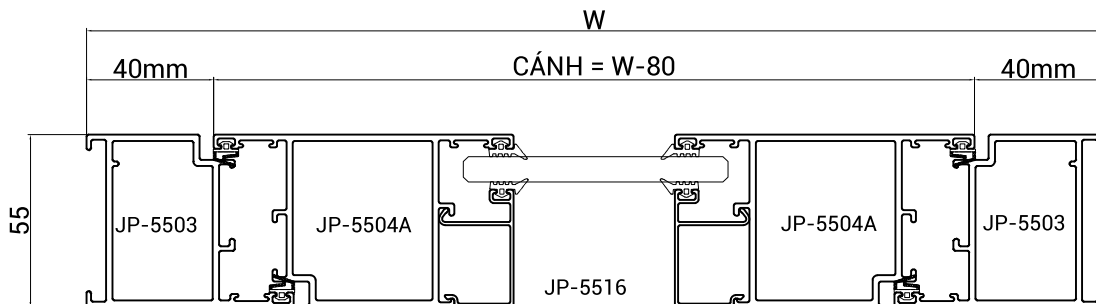
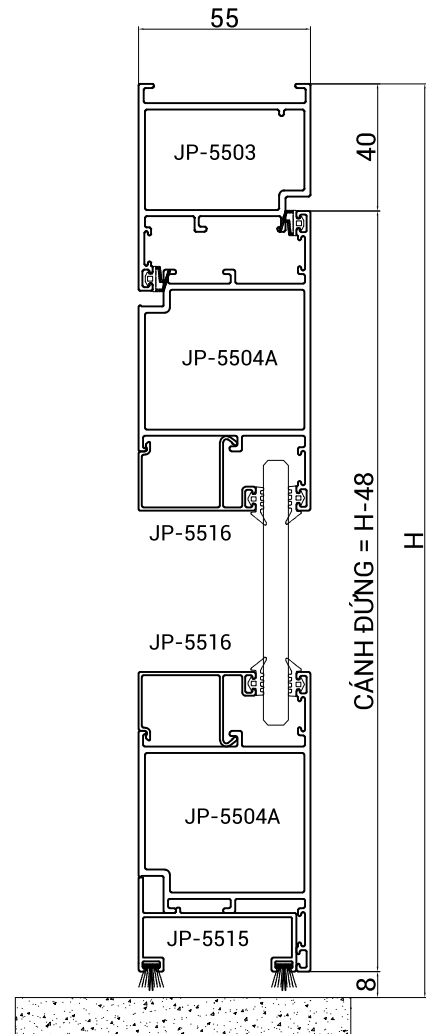
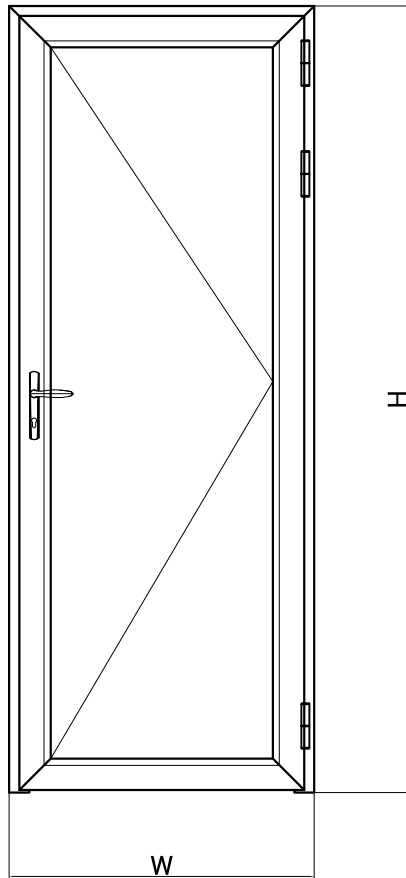

R55

BẢN VẼ LẮP GHÉP |

CỬA ĐI MỞ QUAY |

2 CÁNH

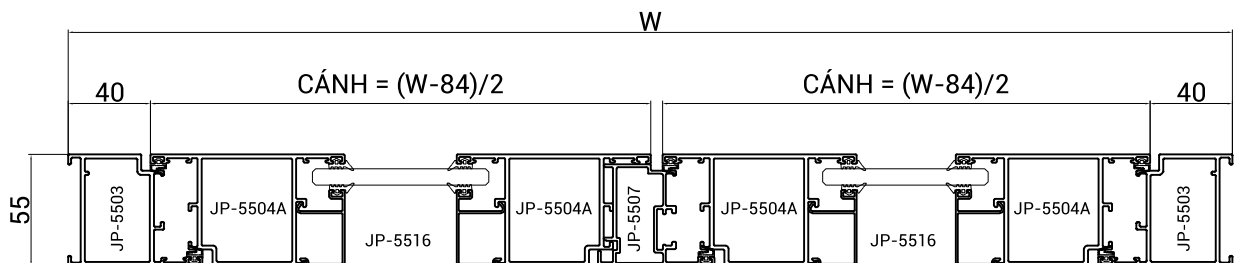
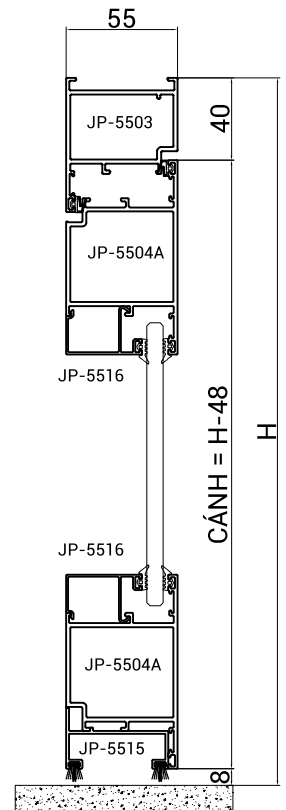
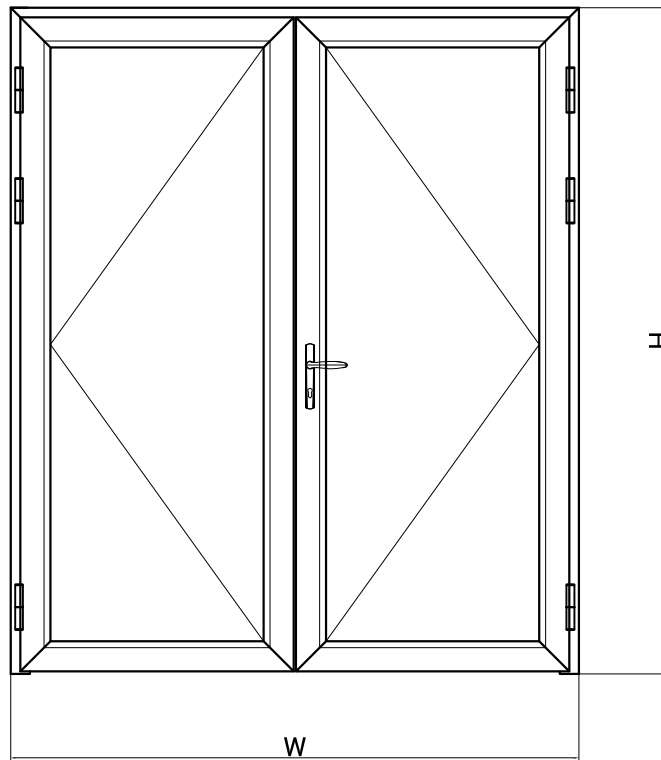

R55

BẢN VẼ LẮP GHÉP |

CỬA ĐI MỞ QUAY |

4 CÁCH

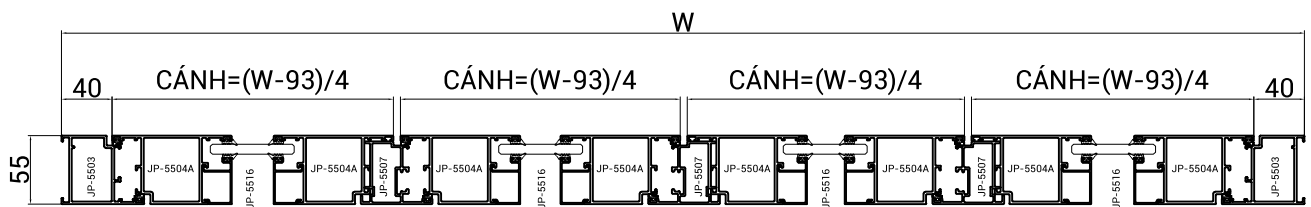
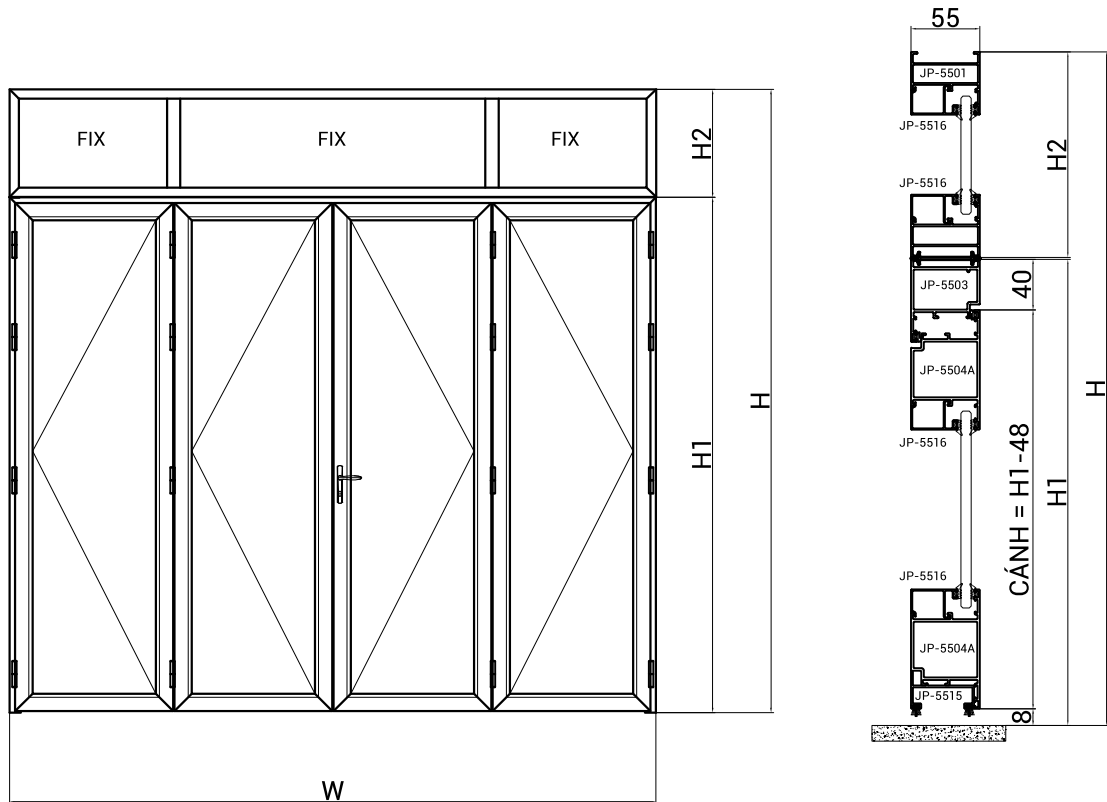

R55

MẶT CẮT - THÔNG SỐ KỸ THUẬT

| CỬA ĐI SỔ MỞ QUAY

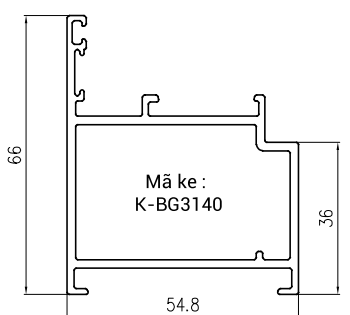
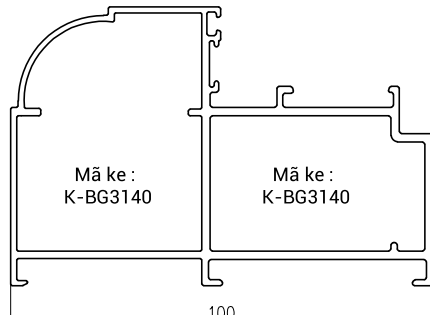
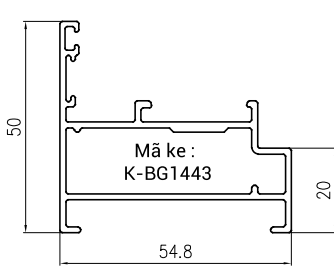
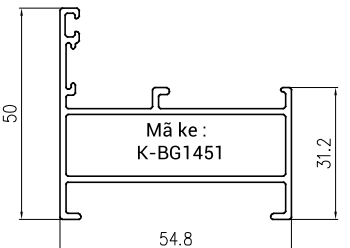
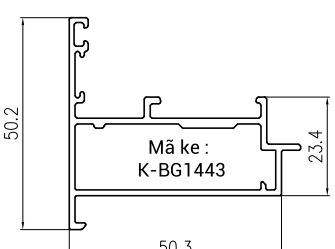
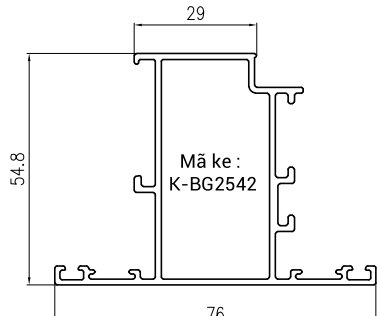
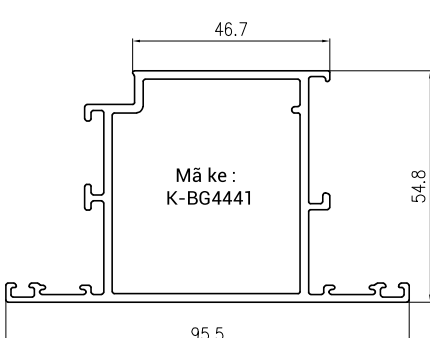
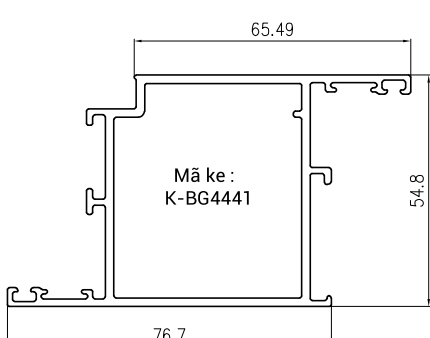
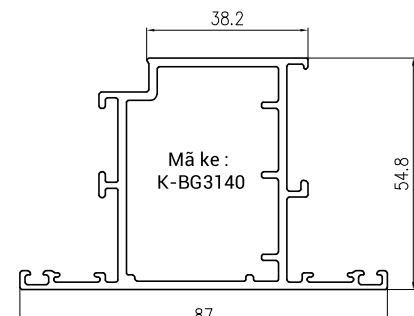
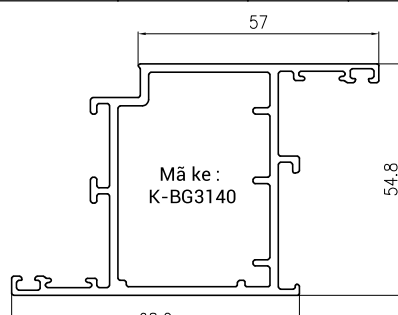
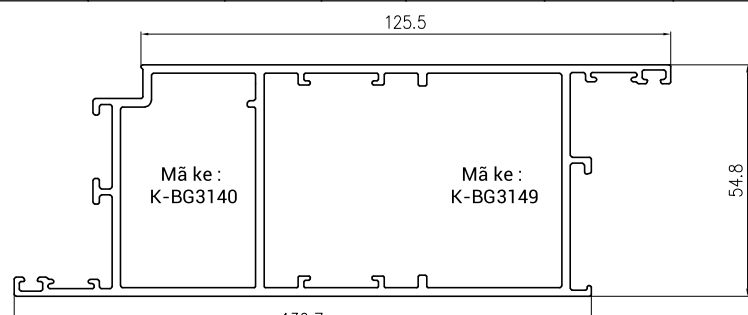
| | | | | | | | | | | | |
|---|----------|-------|-------|--|----------|-------|-------|---|----------|-------|-------|
|  | | | |  | | | |  | | | |
| Khung bao đi 55 | Mã | T(mm) | Kg/m | Khung bao đi 100 | Mã | T(mm) | Kg/m | Khung bao sổ 55 | Mã | T(mm) | Kg/m |
| | JP-5503 | 2.0 | 1.236 | | JP-5521 | 2.0 | 1.879 | | JP-5502 | 1.4 | 0.853 |
|  | | | |  | | | |  | | | |
| Khung bao vách kính | Mã | T(mm) | Kg/m | Khung bao đảo chiều | Mã | T(mm) | Kg/m | Cánh sổ không gân | Mã | T(mm) | Kg/m |
| | JP-5501 | 1.4 | 0.810 | | JP-5525 | 1.4 | 0.792 | | JP-5506 | 1.4 | 1.042 |
|  | | | |  | | | |  | | | |
| Cánh đi mở ra (lớn) | Mã | T(mm) | Kg/m | Cánh đi mở vào (lớn) | Mã | T(mm) | Kg/m | Cánh đi mở ra (nhỏ) | Mã | T(mm) | Kg/m |
| | JP-5504A | 2.0 | 1.5 | | JP-5505A | 2.0 | 1.5 | | JP-5523A | 2.0 | 1.464 |
|  | | | |  | | | | | | | |
| Cánh đi mở vào (nhỏ) | Mã | T(mm) | Kg/m | Cánh đi mở vào dùng khóa thông minh | Mã | T(mm) | Kg/m | | | | |
| | JP-5524A | 2.0 | 1.464 | | JP-5525 | 2.0 | 2.525 | | | | |

R55

MẶT CẮT - THÔNG SỐ KỸ THUẬT

CỬA ĐI SỔ MỞ QUAY

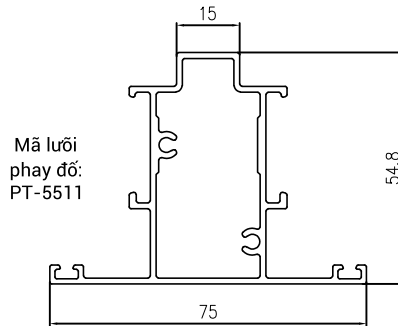
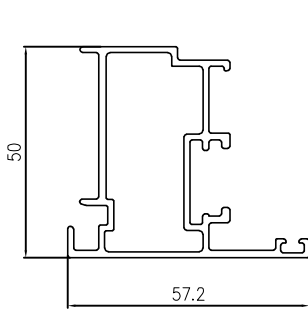

Mã lưới
phay đồ:
PT-5511

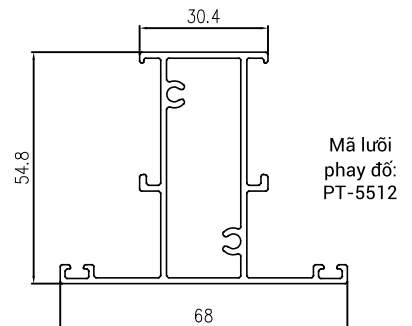

Mã lưới
phay đồ:
PT-5512

| Đổ động | Mã | T(mm) | Kg/m | Đổ tĩnh tách khung | Mã | T(mm) | Kg/m | Đổ tĩnh chia ô | Mã | T(mm) | Kg/m |
|---------|---------|-------|-------|--------------------|---------|-------|-------|----------------|---------|-------|------|
| | JP-5507 | 1.4 | 0.989 | | JP-5511 | 1.4 | 1.055 | | JP-5512 | 1.4 | 0.96 |

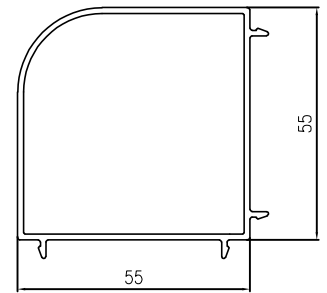
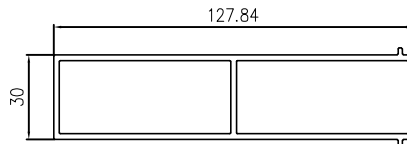
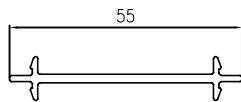

| Ghép khung | Mã | T(mm) | Kg/m | Đổ ghép tăng cứng | Mã | T(mm) | Kg/m | Chuyển góc 90 | Mã | T(mm) | Kg/m |
|------------|---------|-------|-------|-------------------|---------|-------|-------|---------------|---------|-------|-------|
| | JP-5513 | 2.0 | 0.347 | | JP-8328 | 2.0 | 1.841 | | JP-5514 | 1.4 | 0.852 |

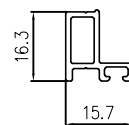
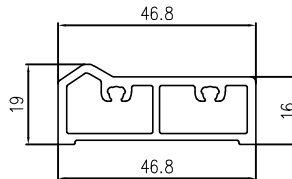
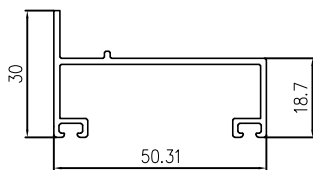

| Ốp chân cánh | Mã | T(mm) | Kg/m | Ngưỡng nhôm | Mã | T(mm) | Kg/m | Ốp ngưỡng nhôm | Mã | T(mm) | Kg/m |
|--------------|---------|-------|-------|-------------|---------|-------|-------|----------------|---------|-------|-------|
| | JP-5515 | 1.4 | 0.448 | | JP-5522 | 2.0 | 0.743 | | JP-8320 | 1.2 | 0.186 |

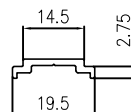
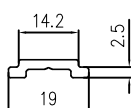

| Thanh truyền động | Mã | T(mm) | Kg/m | Thanh truyền động | Mã | T(mm) | Kg/m |
|-------------------|---------|-------|------|-------------------|---------|-------|-------|
| | JP-8316 | 2.3 | 0.14 | | JP-7018 | 1.5 | 0.106 |

R55

MẶT CẮT - THÔNG SỐ KỸ THUẬT

| CỬA ĐI SỔ MỞ QUAY

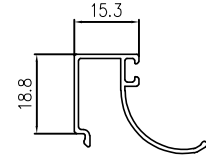
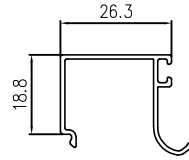
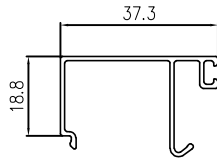

| Nẹp kính 5-12mm | Mã | T(mm) | Kg/m | Nẹp kính hộp | Mã | T(mm) | Kg/m | Nẹp kính rèm | Mã | T(mm) | Kg/m |
|-----------------|---------|-------|-------|--------------|---------|-------|-------|--------------|---------|-------|-------|
| | JP-5516 | 1.0 | 0.276 | | JP-5518 | 1.0 | 0.233 | | JP-5519 | 1.0 | 0.222 |

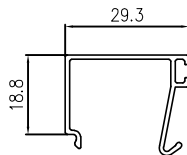

| Nẹp kính khung bao | Mã | T(mm) | Kg/m |
|--------------------|---------|-------|-------|
| | JP-5517 | 1.0 | 0.237 |

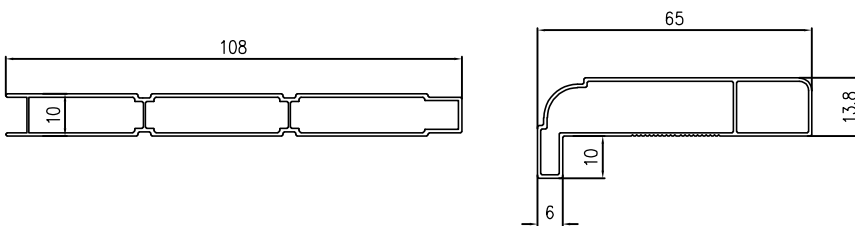



| Pano | Mã | T(mm) | Kg/m | Nẹp chỉ tường | Mã | T(mm) | Kg/m |
|------|---------|-------|-------|---------------|---------|-------|-------|
| | JP-5520 | 0.8 | 0.554 | | JP-8317 | 0.8 | 0.489 |

R55



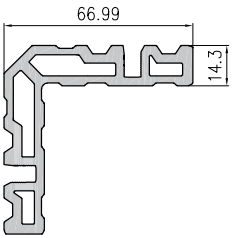
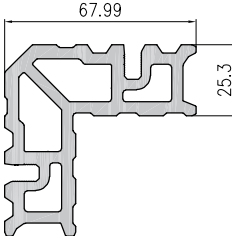
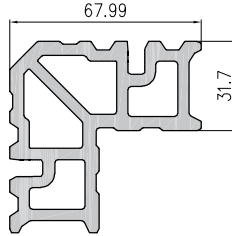
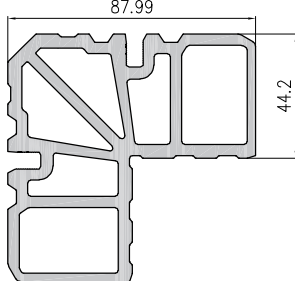







VẬT TƯ PHỤ

ĐỒNG BỘ HỆ R55

| Công năng sử dụng | Mã ke | Quy cách (mm) | Hình ảnh |
|-------------------------------|----------|---------------|---|
| Ke khung bao sổ hệ R55 | K-BG1443 | 14.3 x 43 |  <p>Độ dày: 2.5-3.5 mm</p> |
| Ke khung bao đảo chiều hệ R55 | | | |
| Ke khung bao vách kính hệ R55 | | | |
| | | | |
| Ke cánh sổ hệ R55 | K-BG2542 | 25.3 x 42 |  <p>Độ dày: 4-5 mm</p> |
| Ke khung bao đi hệ R55 | K-BG3140 | 31.7 x 40.5 |  <p>Độ dày: 4-5 mm</p> |
| Ke cánh đi bản nhỏ hệ R55 | | | |
| Ke cánh đi bản lớn hệ R55 | K-BG4441 | 44.2 x 41 |  <p>Độ dày: 4-5 mm</p> |
| Ke tăng cứng inox | --- | --- |  <p>Độ dày: 1 mm</p> |
| | | | Độ dày: 1 mm |

R55

VẬT TƯ PHỤ | ĐỒNG BỘ HỆ R55

| Tên vật tư | Mã gioăng | Hình ảnh |
|--|------------|---|
| GIOĂNG HATSU - PHỐT LÔNG | | |
| Gioăng khung 4 mm | MR-8301H2 |  |
| Gioăng kính 3 mm | MR-8302H1 |  |
| Lông nheo quét chân cánh 5 mm | MR-1565 |  |
| NHỰA | | |
| Nhựa bịt 2 đầu đổ động hệ R55 | DD-5502 |  |
| Nhựa bịt 2 đầu ốp chân cánh hệ R55 (JP-5515) | OC-5501 |  |
| Nhựa gắn ngưỡng nhôm hệ R55 | NN-5501 |  |
| Nhựa bịt 2 đầu ốp ngưỡng nhôm hệ R55 | ON-8301 |  |
| DAO PHAY ĐỔ - DAO BẮM GÓC | | |
| Dao phay đổ chia ô vách kính + cánh hệ R55 | PT-5512 |  |
| Dao phay đổ tách khung hệ R55 | PT-5511 | |
| Dao bấm góc máy TNK dài 95 mm | PT-LBGTNK |  |
| Dao bấm góc máy TQ dài 95 mm | PT-LBGTQ01 |  |
| Dao bấm góc máy TQ dài 120 mm | PT-LBGTQ02 | |