



MAXPRO.JP

JAPAN Aluminium

ĐĂNG CẤP THƯƠNG HIỆU NHÔM NHẬT BẢN

HỆ R65

R65

BẢN VẼ LẮP GHÉP |

CỬA SỔ MỞ QUAY |

1 CÁNH

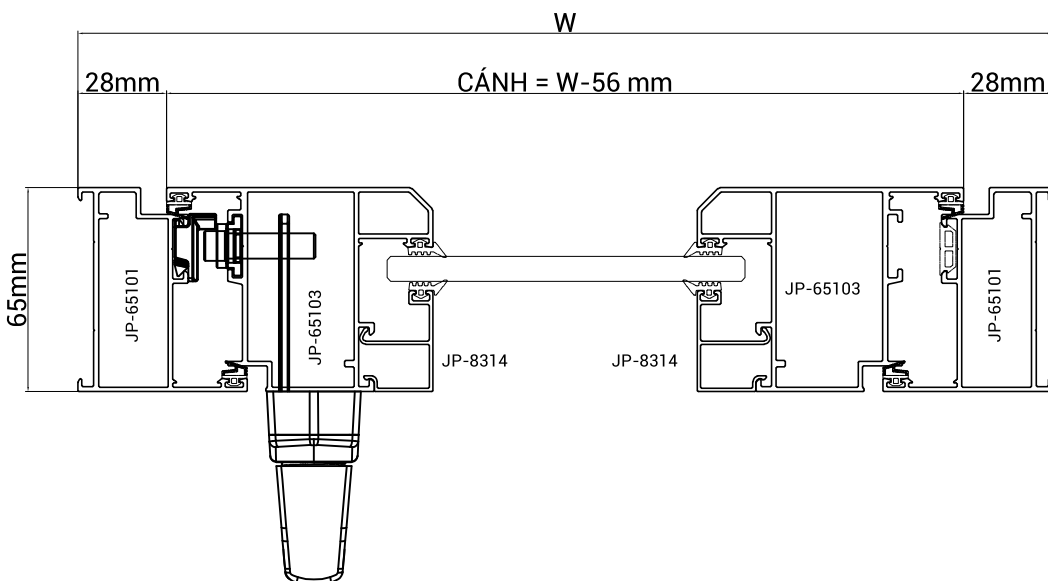
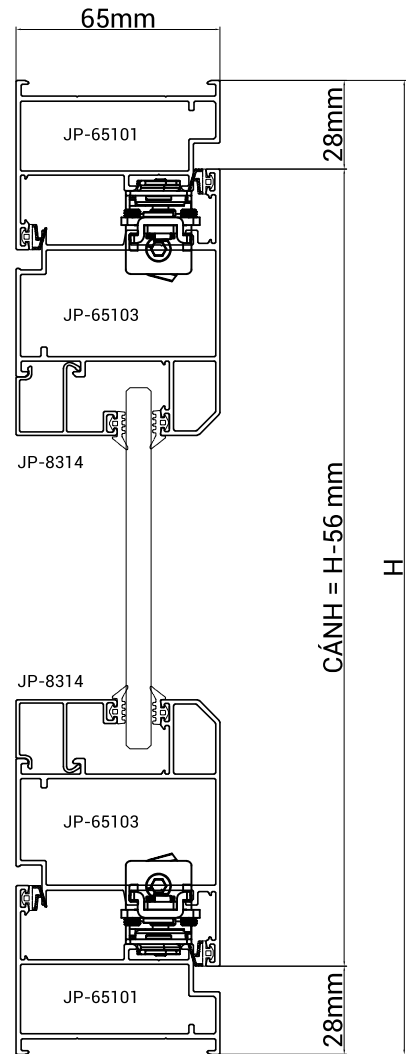
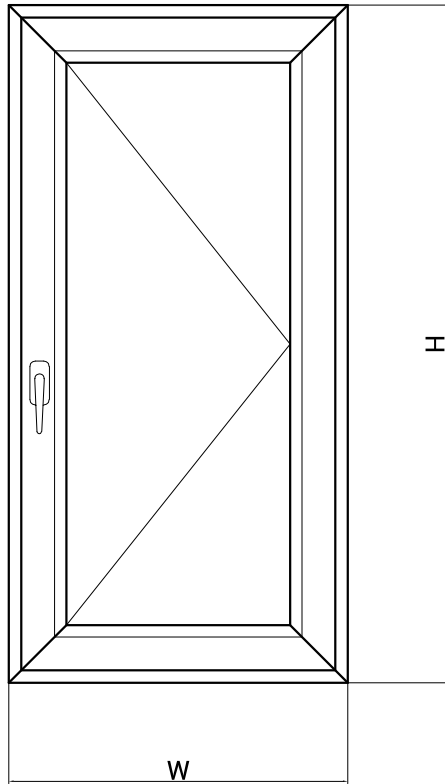

R65

BẢN VẼ LẮP GHÉP |

CỬA SỔ MỞ QUAY |

2 CÁNH

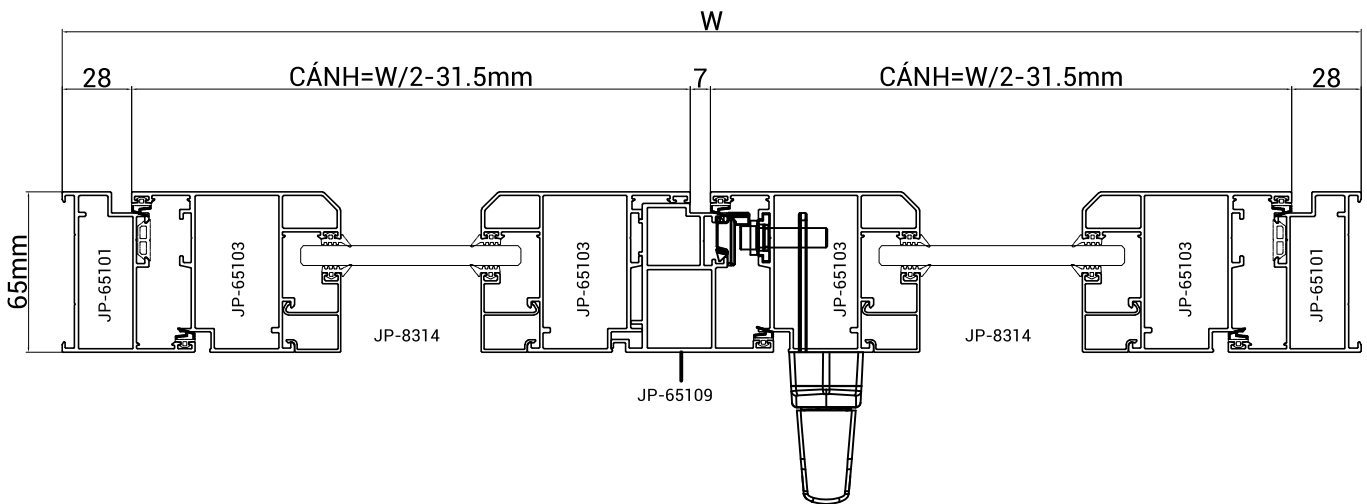
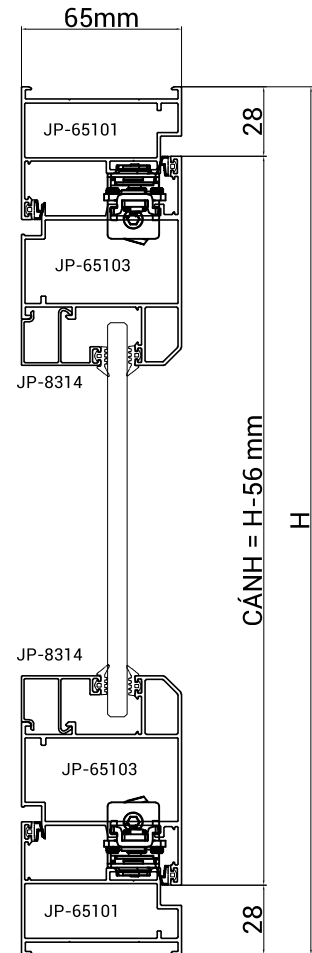
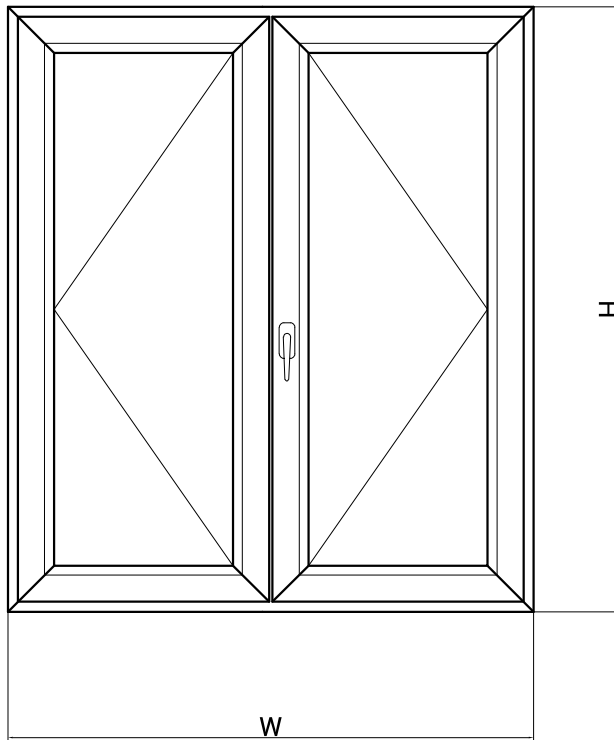

R65

BẢN VẼ LẮP GHÉP |

CỬA SỔ MỞ QUAY |

4 CÁNH

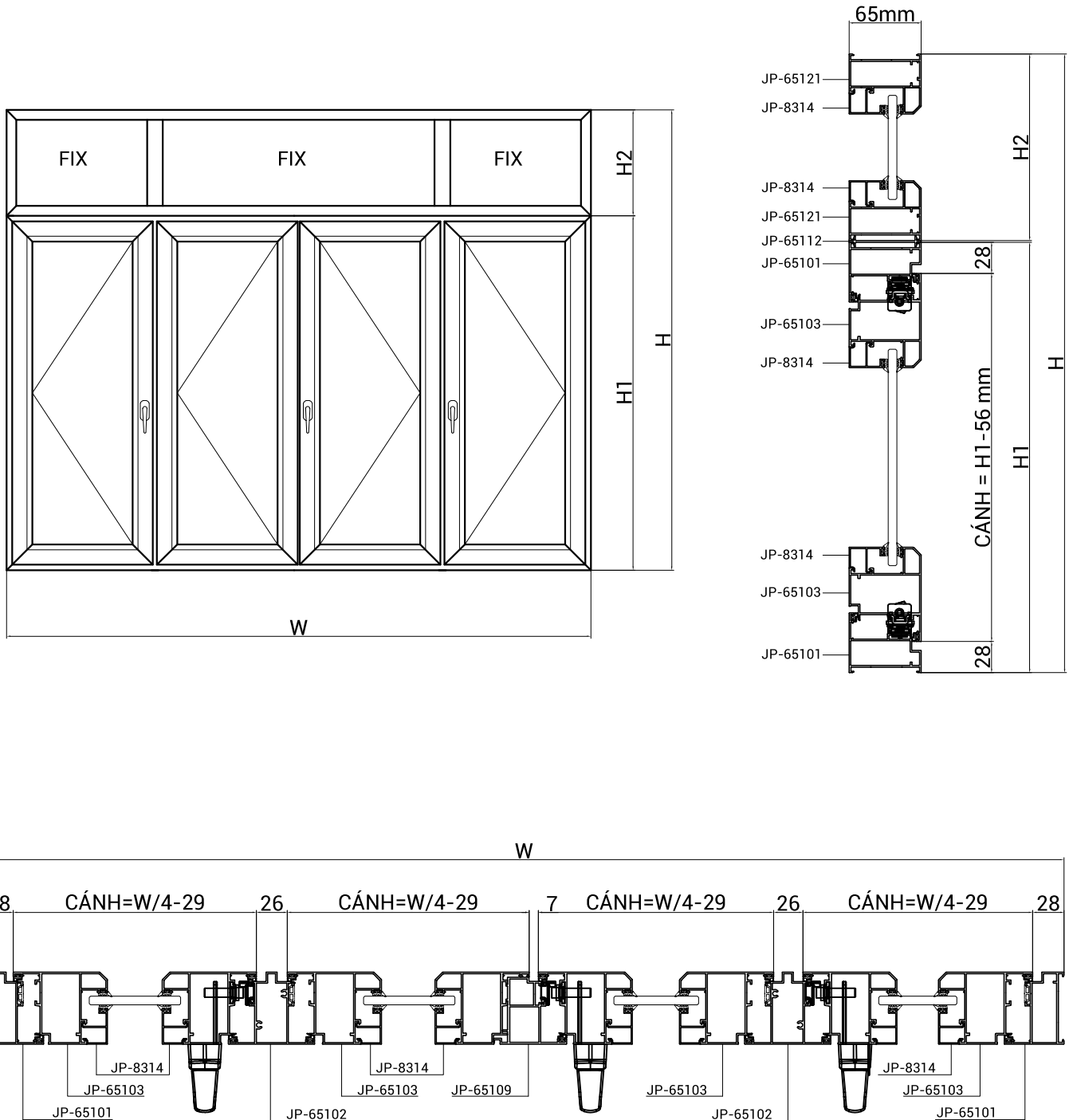

R65

BẢN VẼ LẮP GHÉP |

CỬA ĐI MỞ QUAY |

1 CÁNH

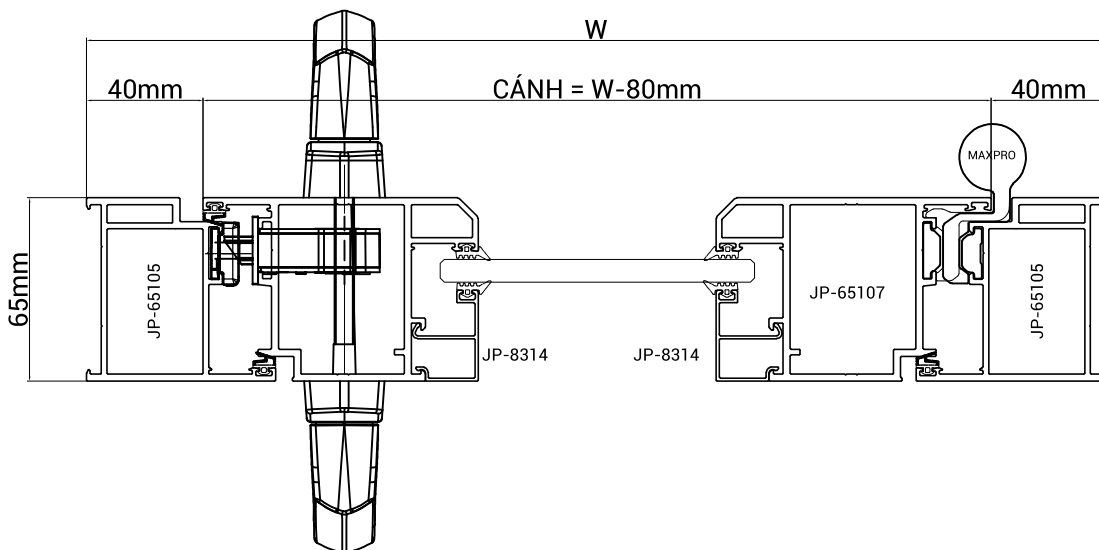
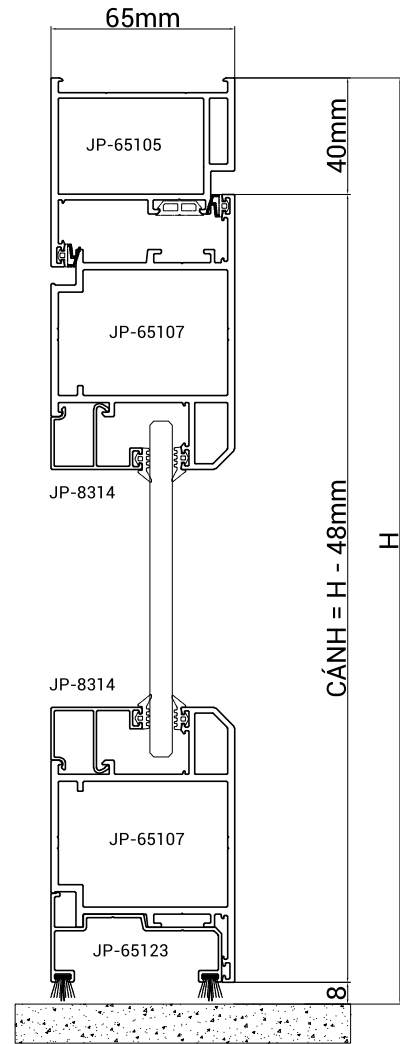
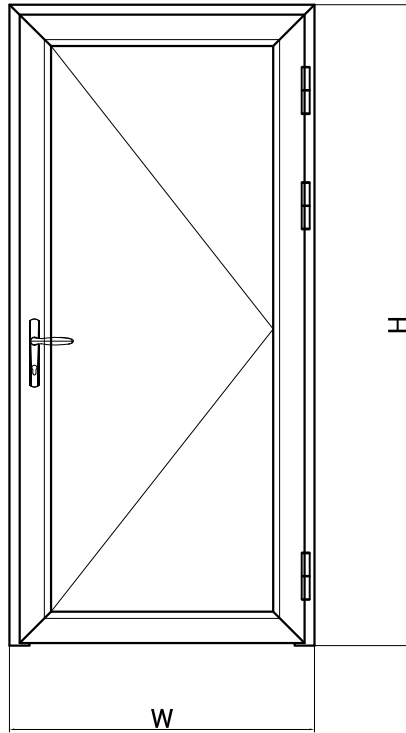

R65

BẢN VẼ LẮP GHÉP |

CỬA ĐI MỞ QUAY |

2 CÁNH

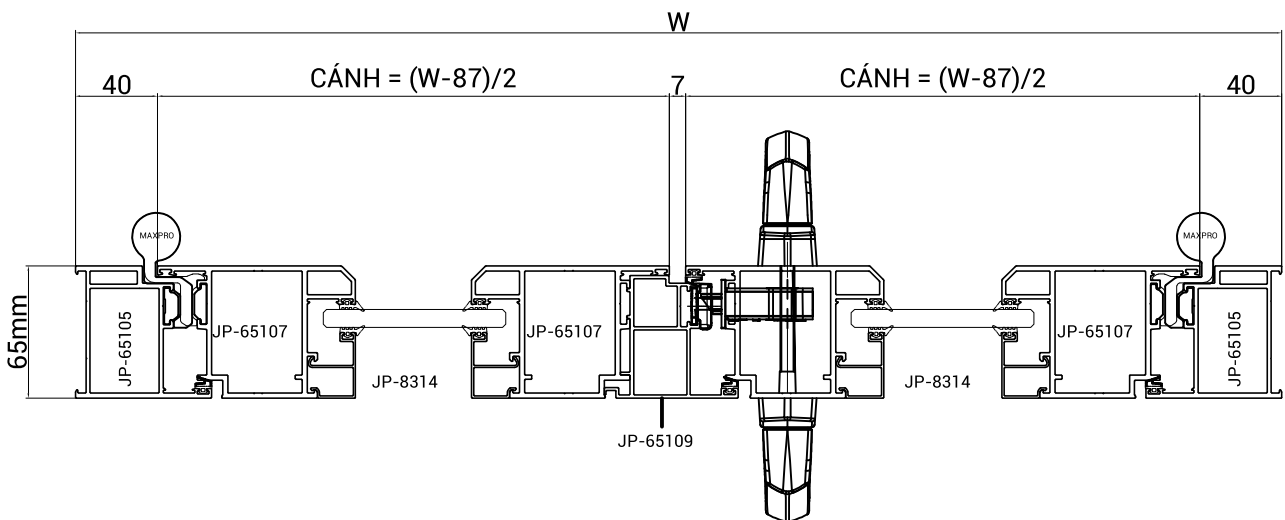
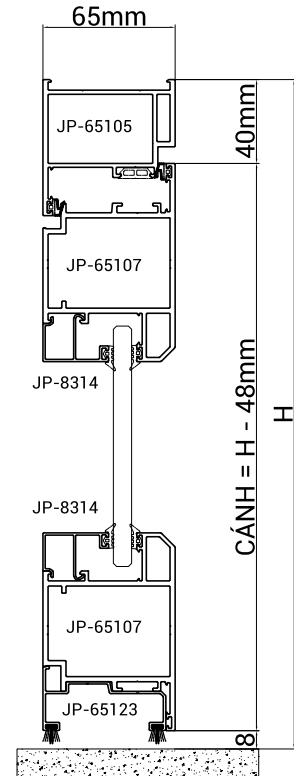
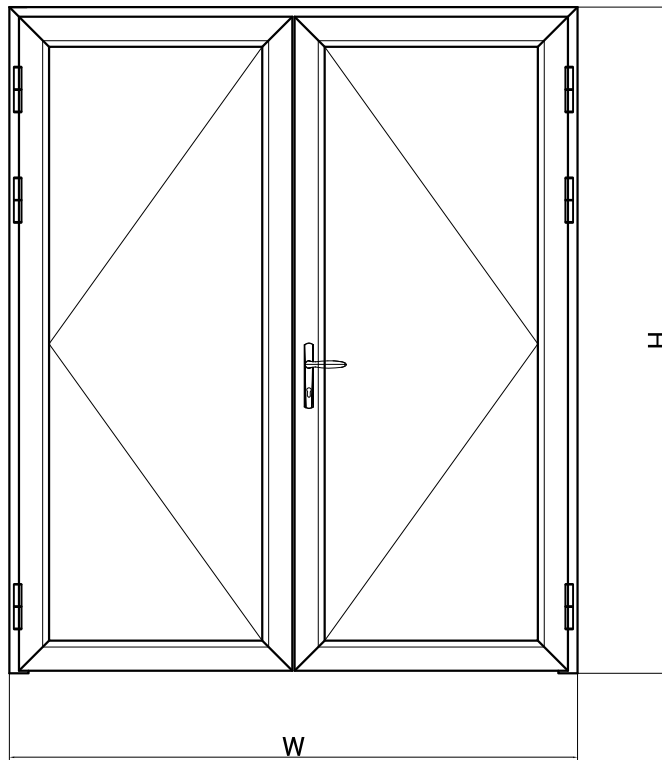

R65

BẢN VẼ LẮP GHÉP |

CỬA ĐI MỞ QUAY |

4 CÁNH

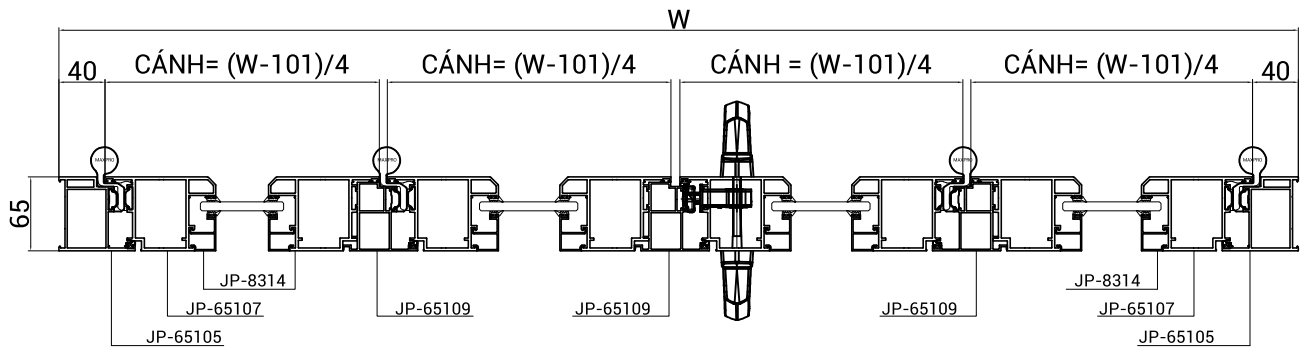
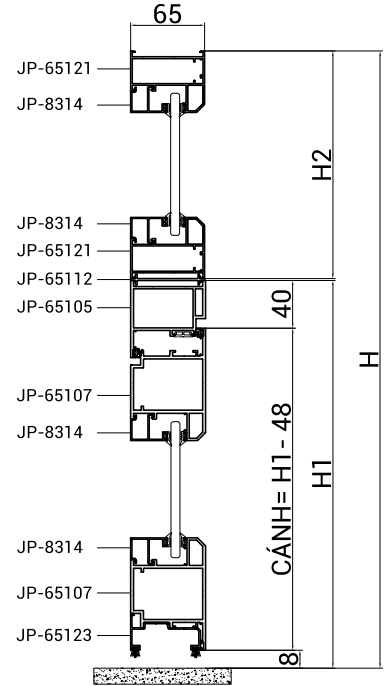
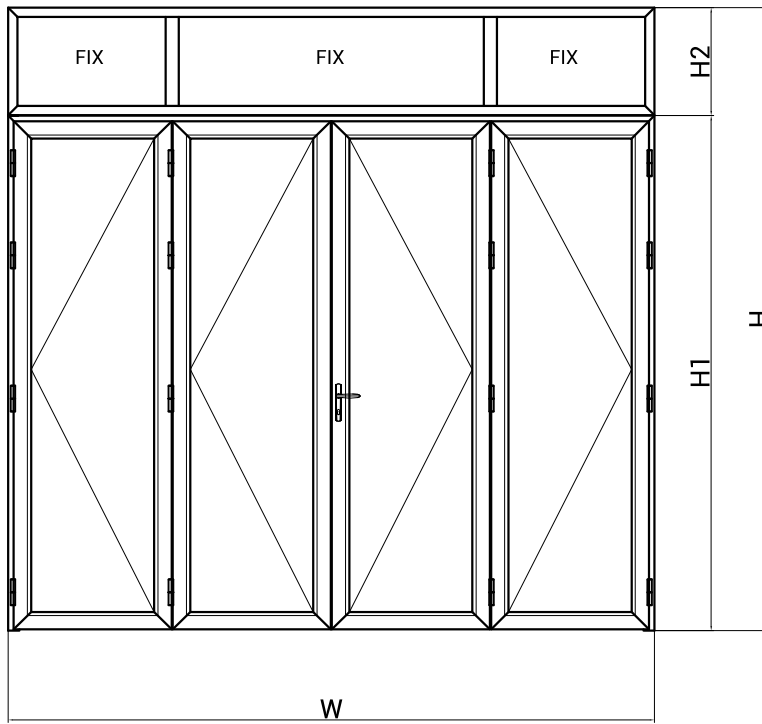

R65

MẶT CẮT - THÔNG SỐ KỸ THUẬT

CỬA ĐI SỔ MỞ QUAY

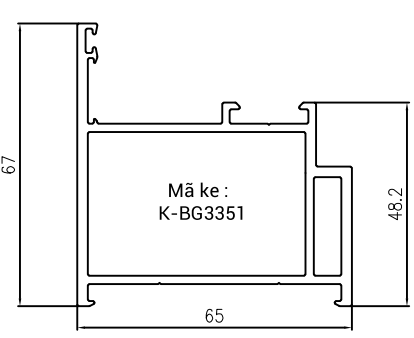
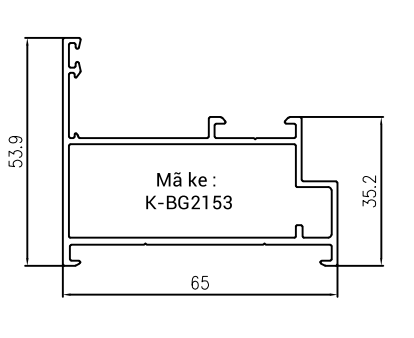
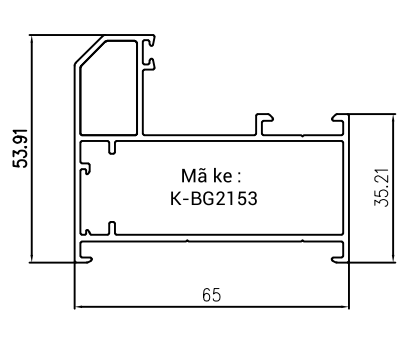
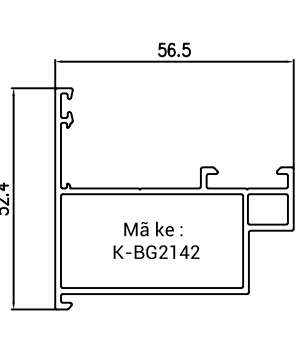
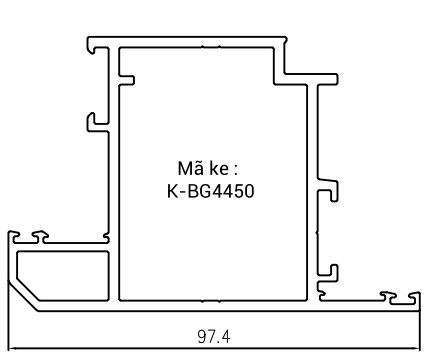
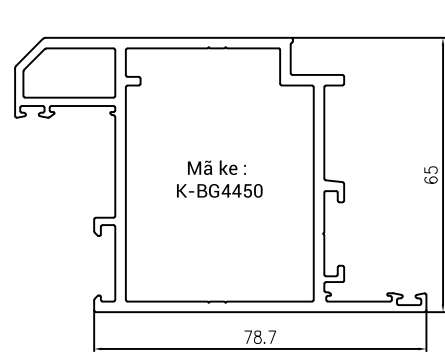
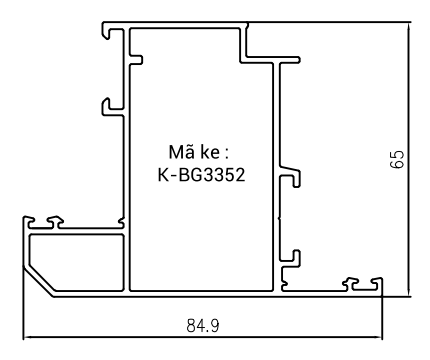
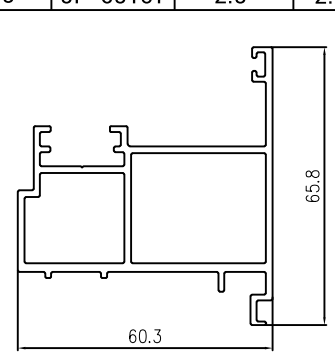
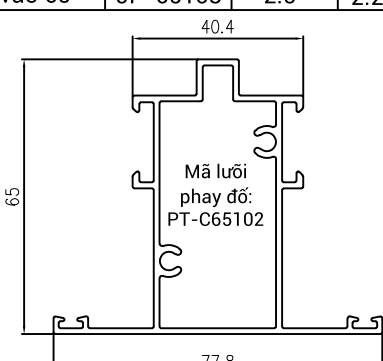
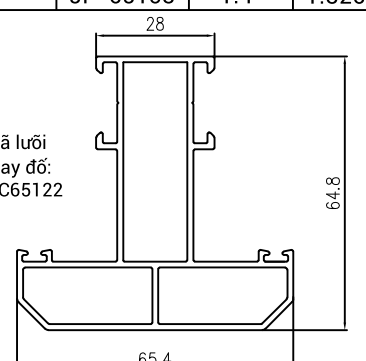
  											
K/B cửa đi 65	Mã JP-65105	T(mm) 2.0-2.5	Kg/m 1.636	K/B cửa sổ 65	Mã JP-65101	T(mm) 1.4	Kg/m 0.948	K/B vách kính 65	Mã JP-65121	T(mm) 1.4	Kg/m 1.091
											
Khung bao đảo chiều	Mã JP-65124	T(mm) 1.4	Kg/m 0.827								
  											
Cánh đi mở ra 65	Mã JP-65107	T(mm) 2.5	Kg/m 2.223	Cánh đi mở vào 65	Mã JP-65108	T(mm) 2.5	Kg/m 2.223	Cánh sổ 65	Mã JP-65103	T(mm) 1.4	Kg/m 1.326
  											
Đổ động sổ + đi 65	Mã JP-65109	T(mm) 1.6-2.0	Kg/m 1.239	Đổ tĩnh tách khung 65	Mã JP-65102	T(mm) 1.4	Kg/m 1.156	Đổ tĩnh chia ô cánh + fix 65	Mã JP-65122	T(mm) 1.4	Kg/m 1.218

R65

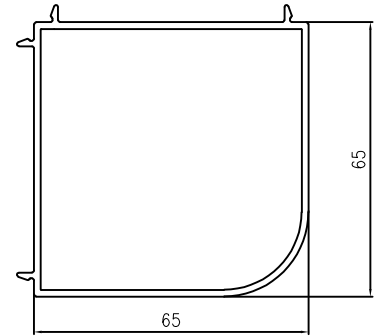
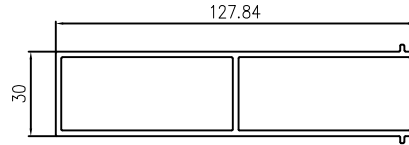
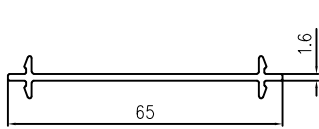
MẶT CẮT - THÔNG SỐ KỸ THUẬT
CỬA ĐI SỔ MỞ QUAY

Ghép khung bao 65	Mã	T(mm)	Kg/m	Đổ ghép tăng cứng	Mã	T(mm)	Kg/m	Chuyển góc 90 độ	Mã	T(mm)	Kg/m
	JP-65112	1.6	0.346		JP-8328	2.0	1.841		JP-65216	1.6	1.130

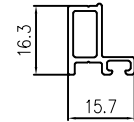
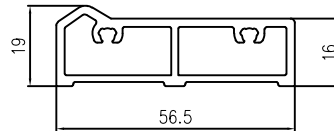
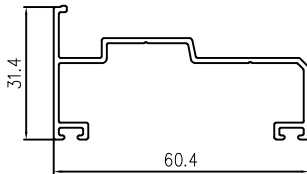

Ốp chân cánh	Mã	T(mm)	Kg/m	Ngưỡng nhôm	Mã	T(mm)	Kg/m	Ốp ngưỡng nhôm	Mã	T(mm)	Kg/m
	JP-65123	1.2	0.465		JP-65214	2.0	0.855		JP-8320	1.2	0.186

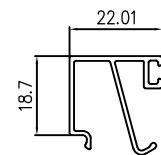
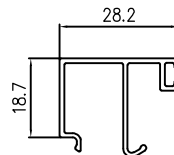
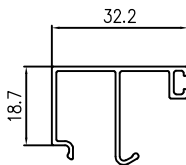

Nẹp kính 8-10mm	Mã	T(mm)	Kg/m	Nẹp kính 12mm	Mã	T(mm)	Kg/m	Nẹp kính hộp 19-21mm	Mã	T(mm)	Kg/m
	JP-8314	1.1	0.279		JP-8327	1.1	0.264		JP-8315	1.1	0.249

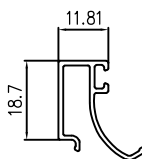

Nẹp kính rèm 33mm	Mã	T(mm)	Kg/m
JP-15227	1.1	0.205	

R65

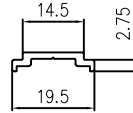
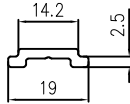
MẶT CẮT - THÔNG SỐ KỸ THUẬT
CỬA ĐI SỔ MỞ QUAY

Thanh truyền động	Mã	T(mm)	Kg/m	Thanh truyền động	Mã	T(mm)	Kg/m
	JP-8316	2.3	0.14		JP-7018	1.5	0.106

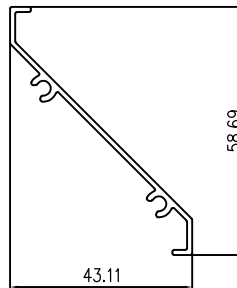
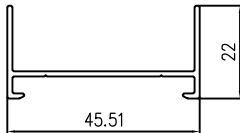

Khung bao lá sách	Mã	T(mm)	Kg/m	Lá sách	Mã	T(mm)	Kg/m
	JP-8323	1.2	0.301		JP-8324	1.2	0.333

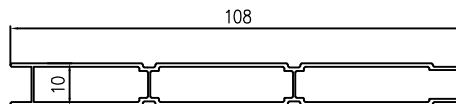
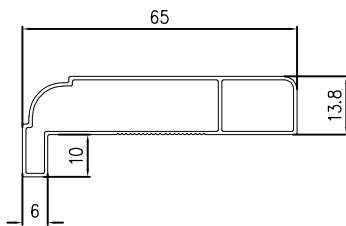

Nẹp chỉ tường	Mã	T(mm)	Kg/m	Pano	Mã	T(mm)	Kg/m
	JP-8317	0.8	0.489		JP-5520	0.8	0.554

R65





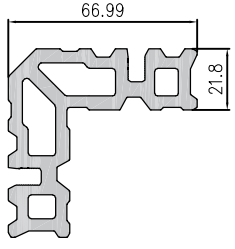
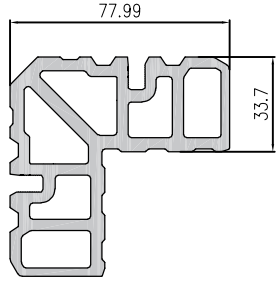
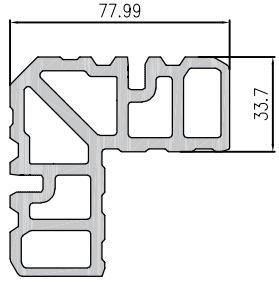
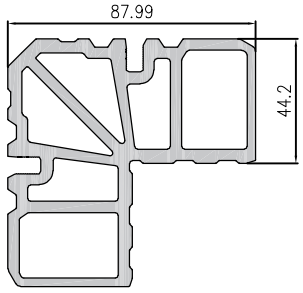
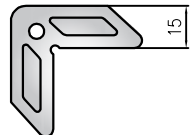





VẬT TƯ PHỤ

ĐỒNG BỘ HỆ R65

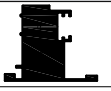
Công năng sử dụng	Mã ke	Quy cách (mm)	Hình ảnh
Ke khung bao sổ hệ R65	K-BG2153	21.8 x 52.5	 <p>Độ dày: 4-5 mm</p>
Ke khung bao vách kính hệ R65			
Ke khung bao đảo chiều hệ R65			
Ke khung bao đi hệ R65	K-BG3350	33.7 x 50	 <p>Độ dày: 4-5 mm</p>
Ke cánh sổ hệ R65	K-BG3352	33.7 x 52	 <p>Độ dày: 4-5 mm</p>
Ke cánh đi hệ R65	K-BG4450	44.2 x 50	 <p>Độ dày: 4-5 mm</p>
Ke tăng cứng inox hệ R58, R65, R65 plus, SFD80, R83, SD115	K-TC42154B	42 x 15	 <p>Độ dày: 1 mm</p>

R65

VẬT TƯ PHỤ | ĐỒNG BỘ HỆ R65

Tên vật tư	Mã gioăng	Hình ảnh
GIOĂNG HATSU - PHỐT LÔNG		
Gioăng khung 4 mm	MR-8301H2	
Gioăng kính 3 mm	MR-8302H1	
Gioăng đáy rãnh khung bao	MR-1504H1	
Lông nheo quét chân cánh 5 mm	MR-1565	
NHỰA		
Nhựa bịt 2 đầu đổ động hệ R65	DD-6501	
Nhựa bịt 2 đầu ốp chân cánh hệ R65 (JP-65123)	OC-6501	
Nhựa gắn ngưỡng nhôm hệ R65	NN-6501	
Nhựa bịt 2 đầu ốp ngưỡng nhôm hệ R65	ON-6501	
DAO PHAY ĐỔ - DAO BẮM GÓC		
Dao phay đổ chia ô vách kính + cánh hệ R65	PT-65122	
Dao phay đổ tách khung hệ R65	PT-65102	
Dao bấm góc máy TNK dài 95 mm	PT-LBGTNK	
Dao bấm góc máy TQ dài 95 mm	PT-LBGTQ01	
Dao bấm góc máy TQ dài 120 mm	PT-LBGTQ02	