



**MAXPRO.JP**

***JAPAN Aluminium***

ĐĂNG CẤP THƯƠNG HIỆU NHÔM NHẬT BẢN

**HỆ R83**

# R83

BẢN VẼ LẮP GHÉP |

CỬA SỐ MỞ QUAY |

1 CÁNH

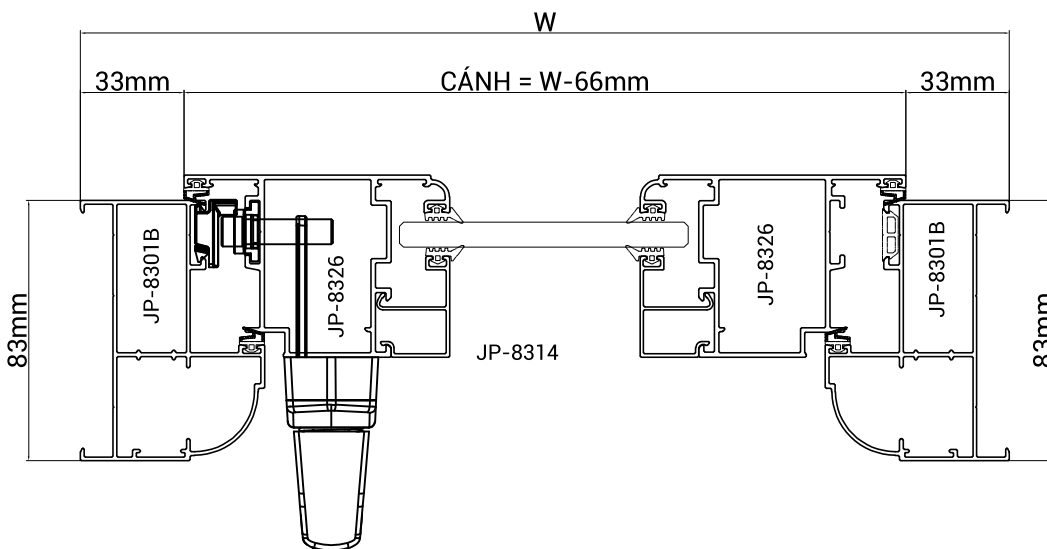
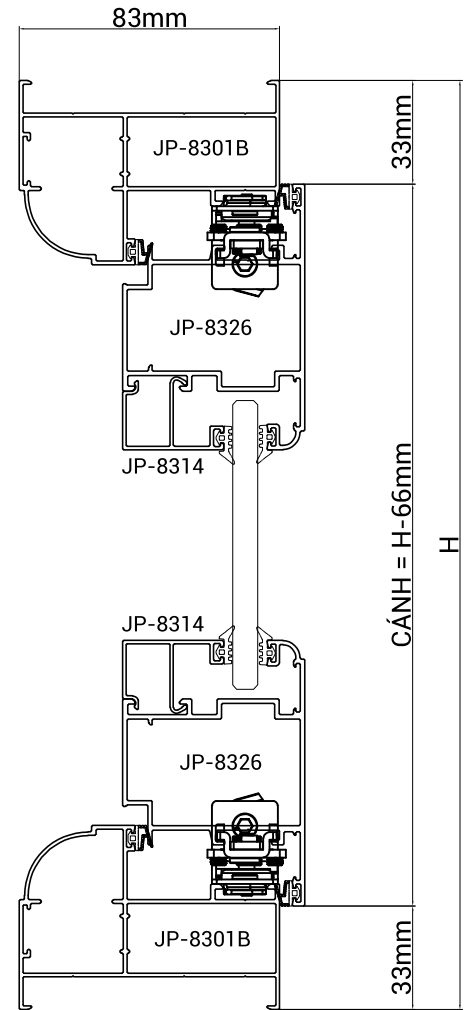
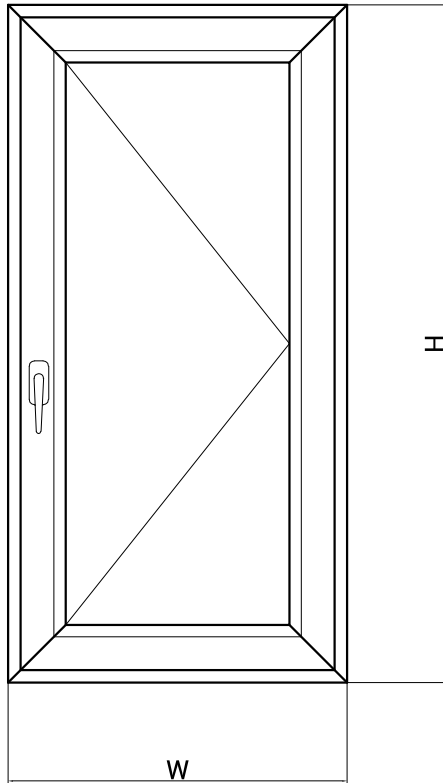

# R83

BẢN VẼ LẮP GHÉP |

CỬA SỐ MỞ QUAY |

2 CÁNH

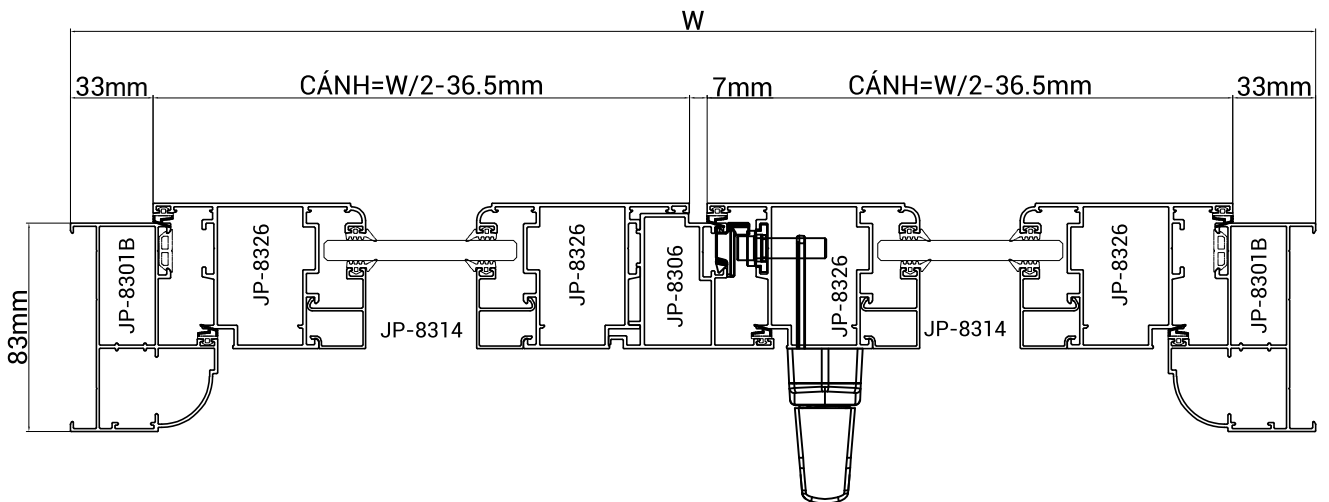
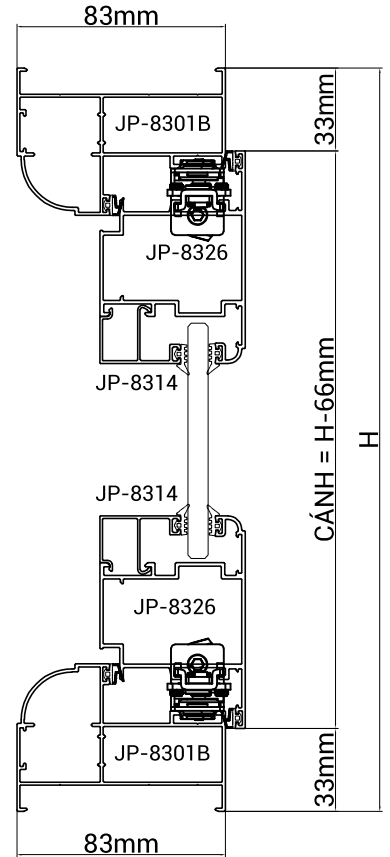
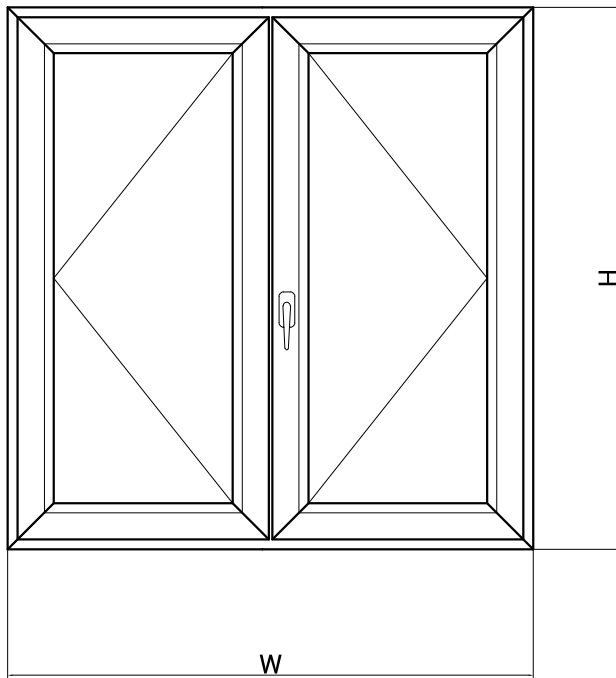

# R83

BẢN VẼ LẮP GHÉP |

CỬA SỐ MỞ QUAY |

4 CÁNH

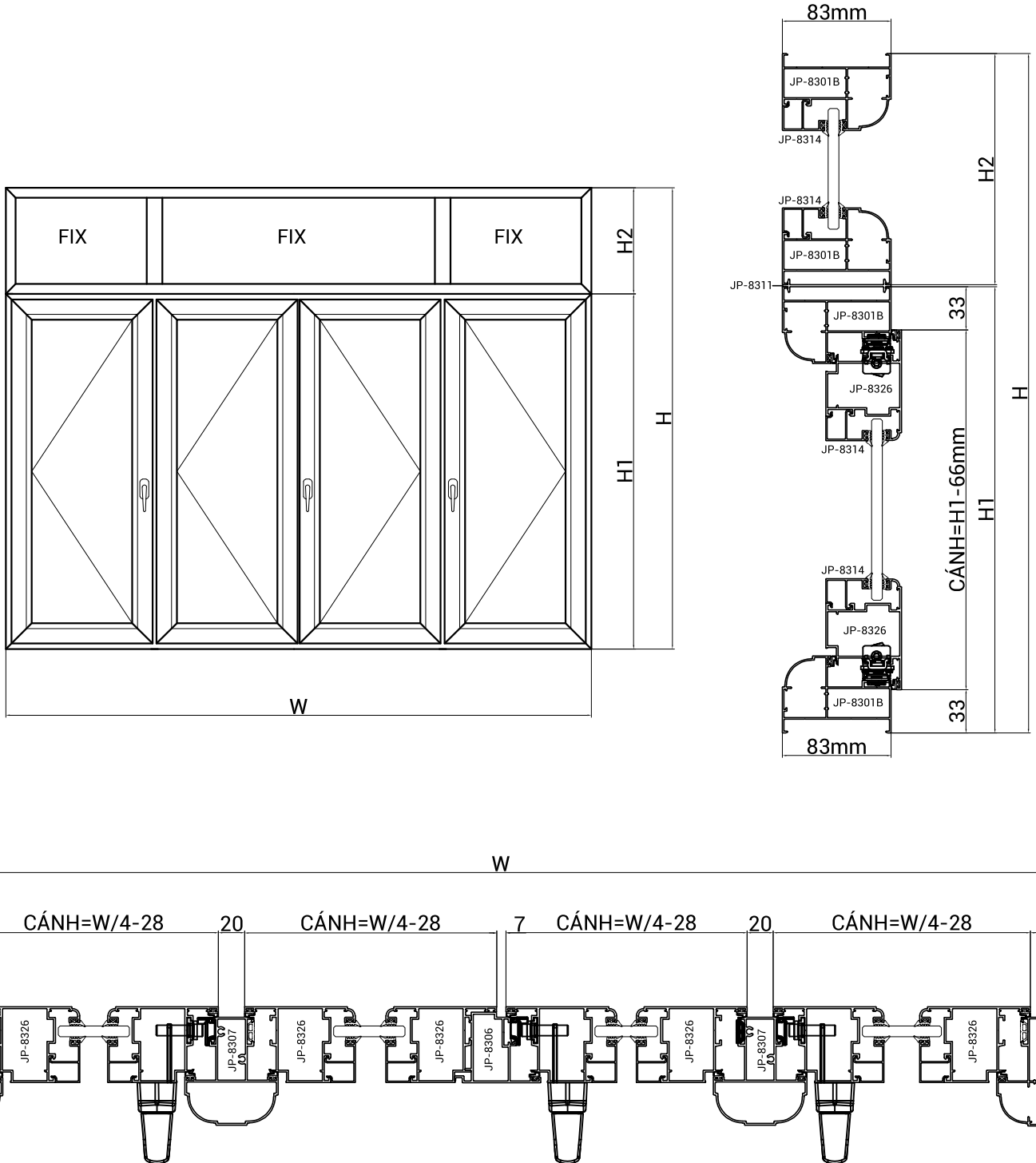

# R83

BẢN VẼ LẮP GHÉP |

CỬA ĐI MỞ QUAY |

1 CÁNH

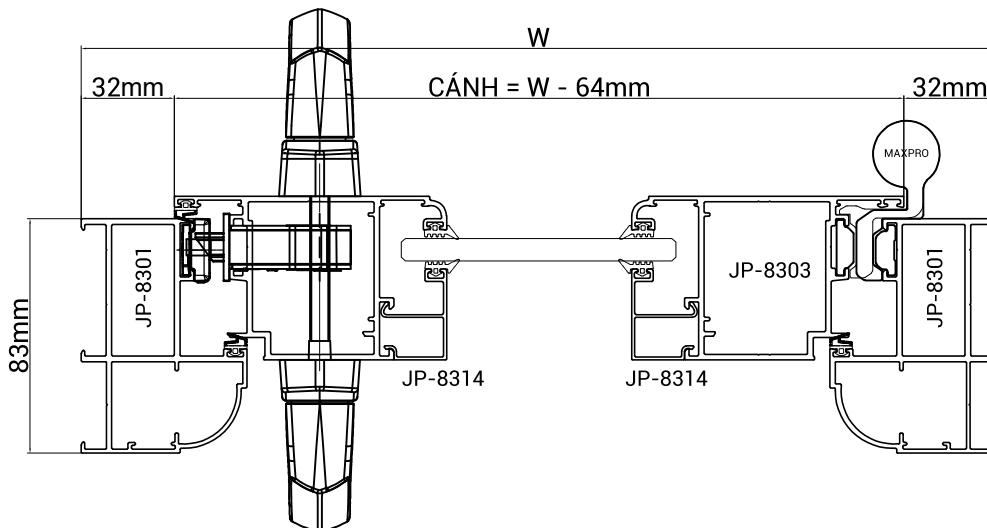
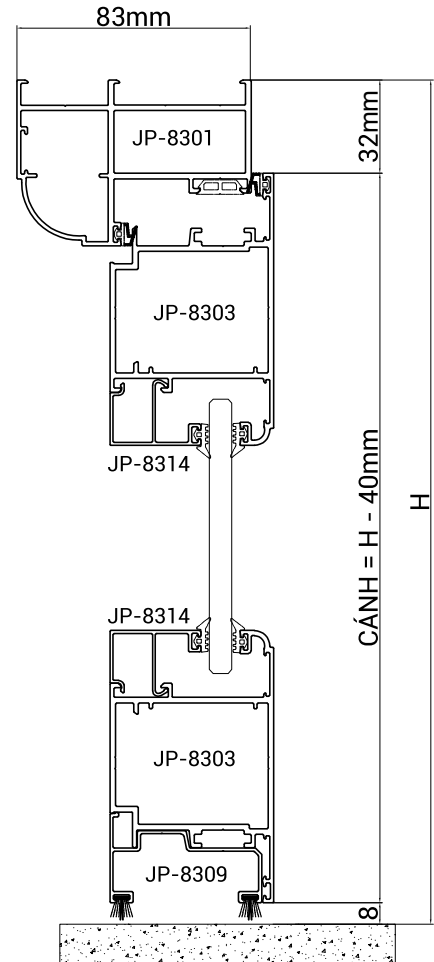
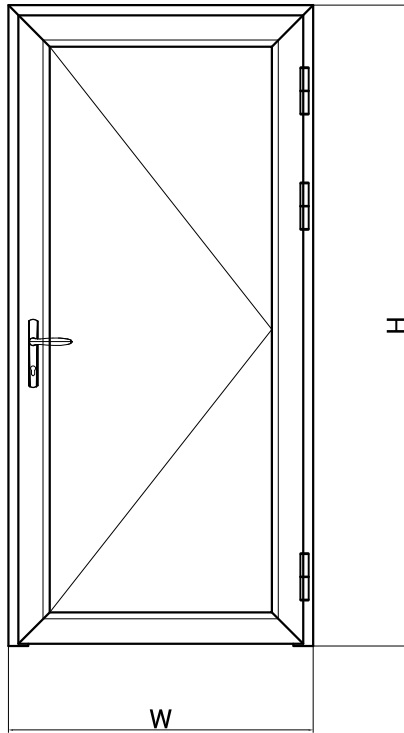

# R83

BẢN VẼ LẮP GHÉP |

CỬA ĐI MỞ QUAY |

2 CÁNH

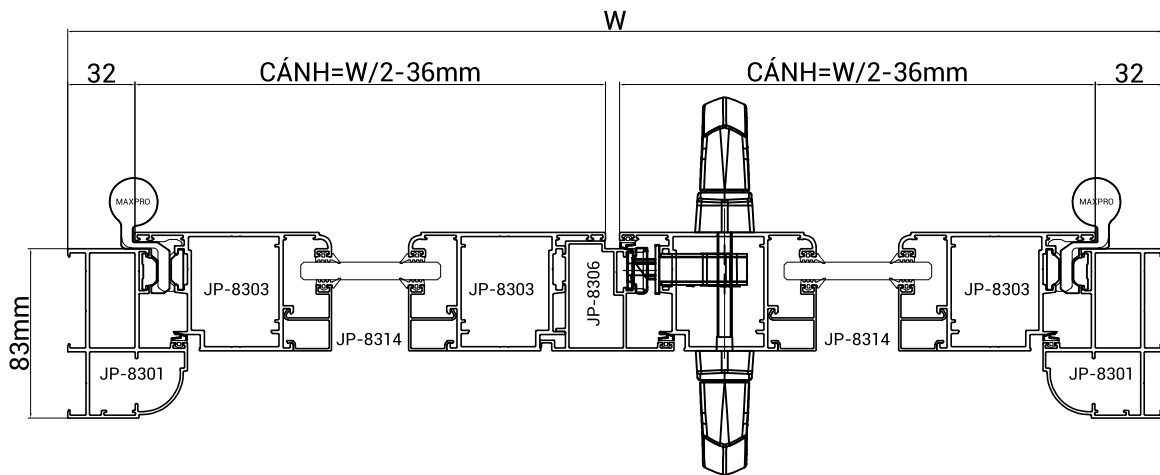
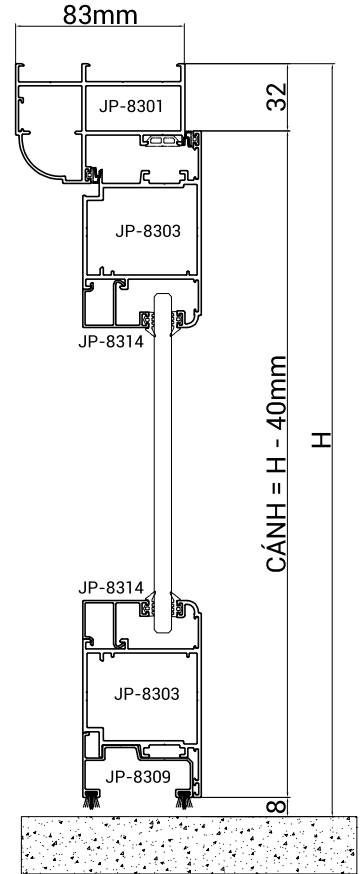
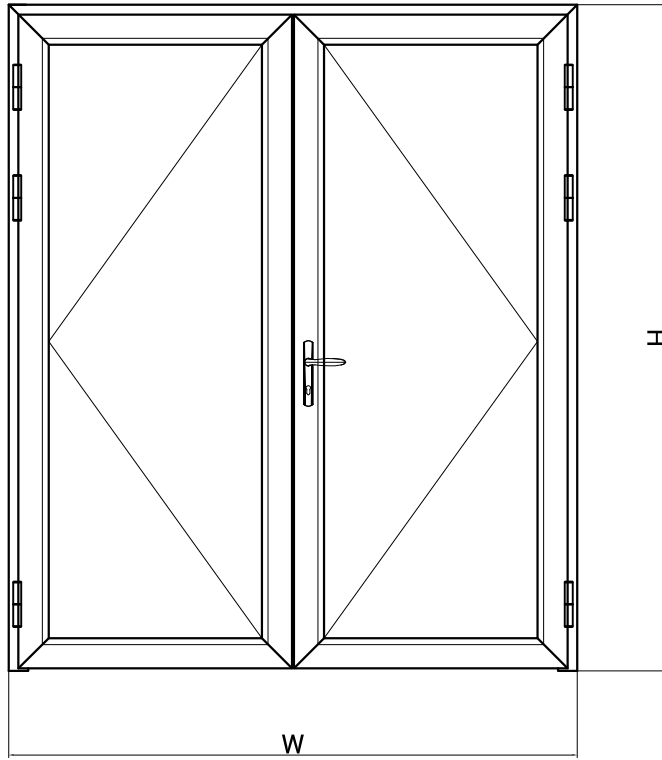

# R83

BẢN VẼ LẮP GHÉP |

CỬA ĐI MỞ QUAY |

4 CÁNH

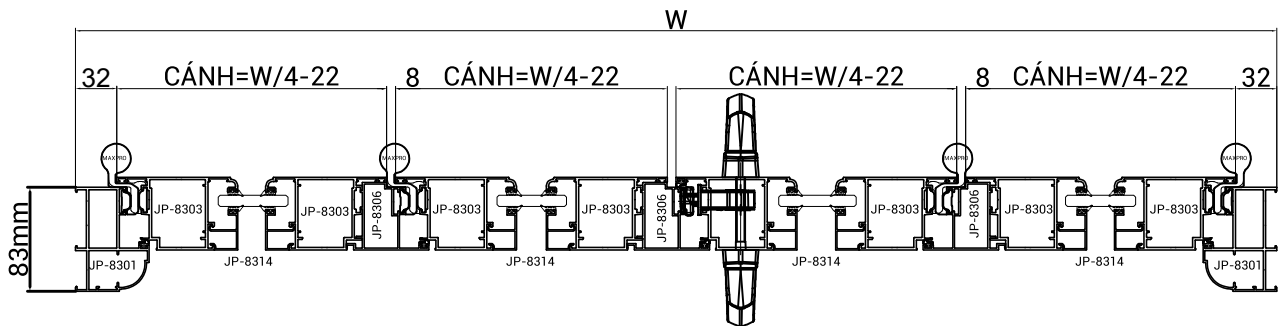
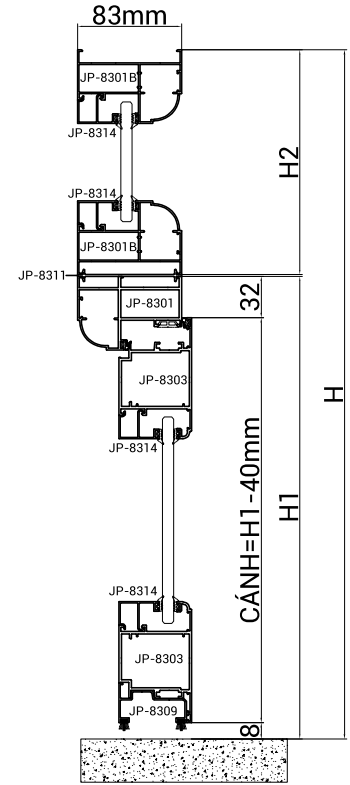
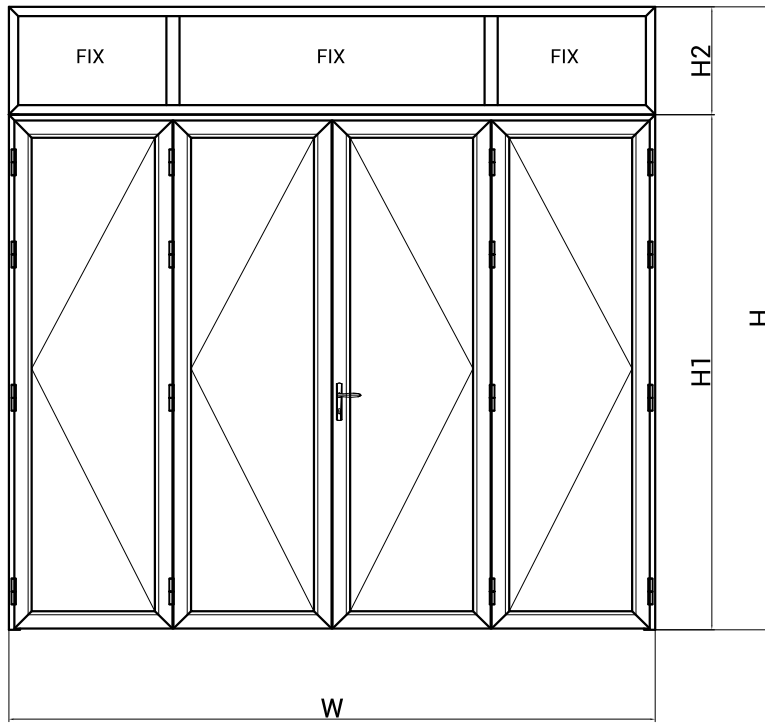

# R83

MẶT CẮT - THÔNG SỐ KỸ THUẬT

CỬA ĐI SỐ MỞ QUAY

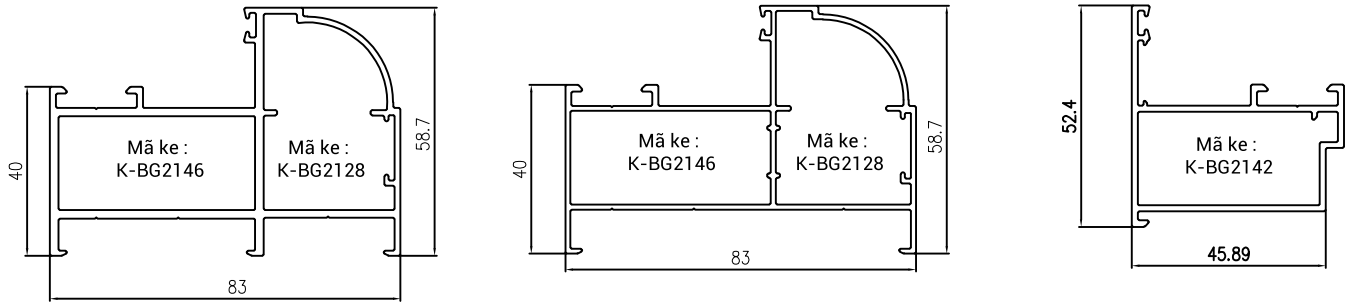

K/B cửa đi	Mã	T(mm)	Kg/m	K/B fix + cửa số 83	Mã	T(mm)	Kg/m	Khung bao đảo chiều	Mã	T(mm)	Kg/m
83	JP-8301	1.4-2.0	1.621		JP-8301B	1.4	1.259		JP-8329	1.4	0.760

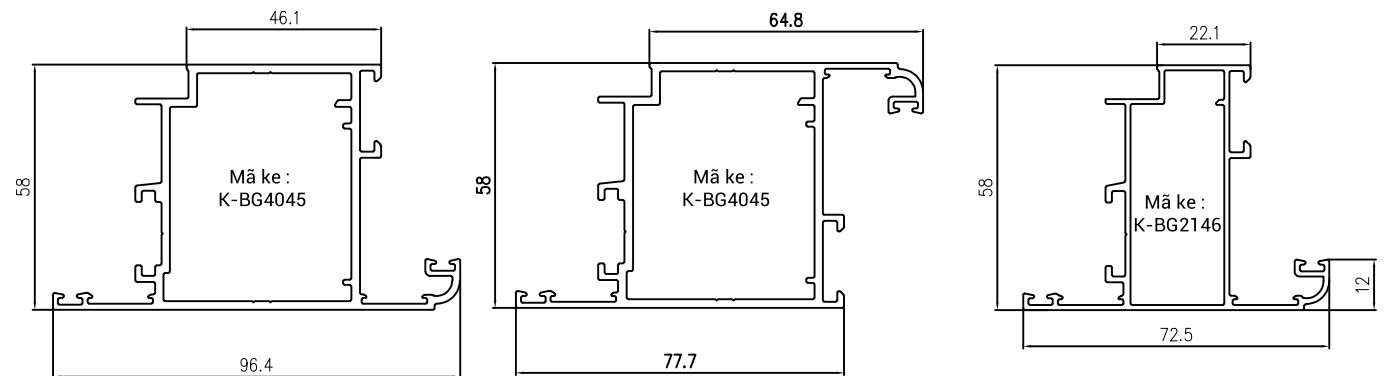

Cánh đi mở ngoài	Mã	T(mm)	Kg/m	Cánh đi mở trong	Mã	T(mm)	Kg/m	Cánh cửa số	Mã	T(mm)	Kg/m
	JP-8303	2.0	1.604		JP-8304	2.0	1.604		JP-8305	1.4	1.051

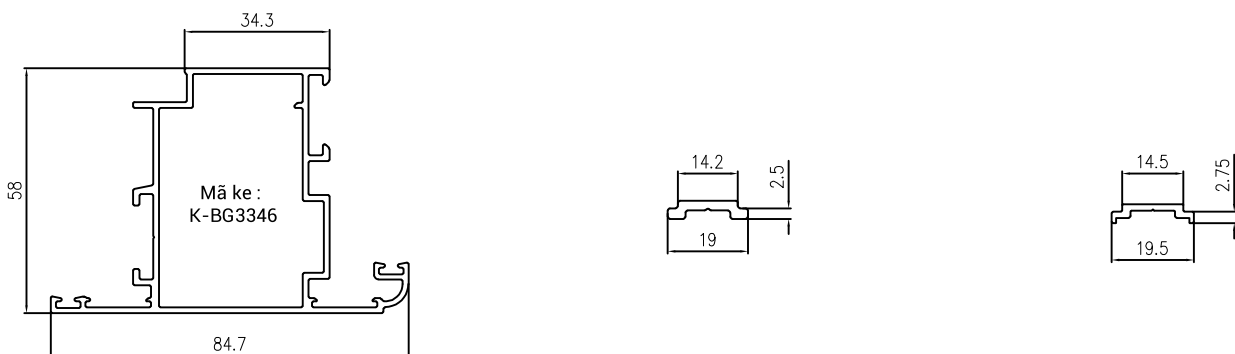

Cánh cửa số quay hất	Mã	T(mm)	Kg/m	Thanh truyền động	Mã	T(mm)	Kg/m	Thanh truyền động	Mã	T(mm)	Kg/m
	JP-8326	1.4	1.181		JP-8316	2.3	0.14		JP-7018	1.5	0.106

# R83

MẶT CẮT - THÔNG SỐ KỸ THUẬT

CỬA ĐI SỐ MỞ QUAY

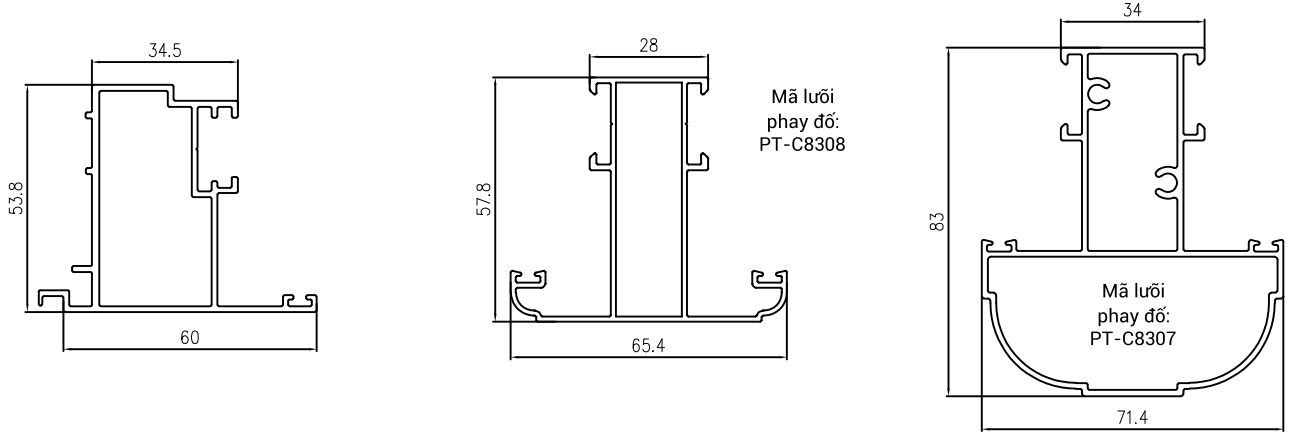

Đồ động số, đi	Mã	T(mm)	Kg/m	Đồ chia ô cánh	Mã	T(mm)	Kg/m	Đồ tĩnh fix 83	Mã	T(mm)	Kg/m
	JP-8306	1.4-1.7	0.96		JP-8308	1.2	0.88		JP-8307	1.4	1.437

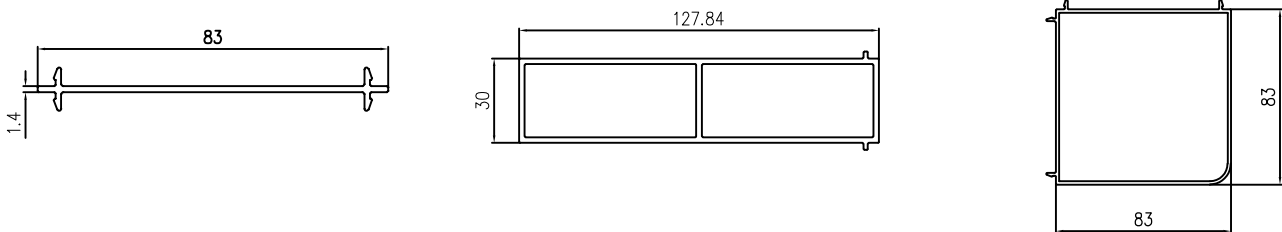

Nổi khuôn 83	Mã	T(mm)	Kg/m	Đồ ghép tăng cứng	Mã	T(mm)	Kg/m	Chuyển góc	Mã	T(mm)	Kg/m
	JP-8311	1.4	0.383		JP-8328	2.0	1.841		JP-8318	1.6	1.470

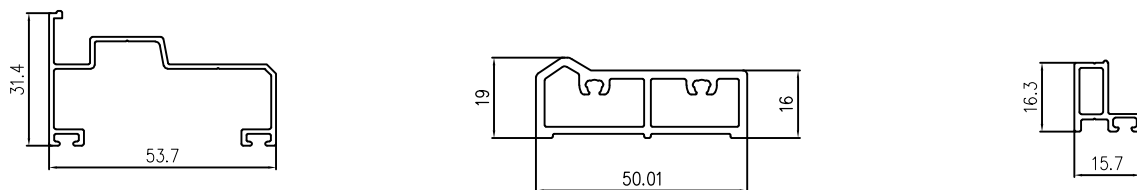

Ốp chân cánh	Mã	T(mm)	Kg/m	Ngưỡng nhôm	Mã	T(mm)	Kg/m	Ốp ngưỡng nhôm	Mã	T(mm)	Kg/m
	JP-8309	1.2	0.421		JP-8319	1.6-2.0	0.780		JP-8320	1.2	0.186

# R83

MẶT CẮT - THÔNG SỐ KỸ THUẬT

| CỬA ĐI SỐ MỞ QUAY

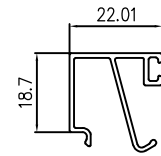
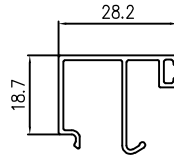
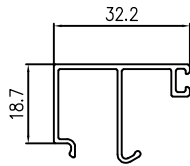

Nẹp kính 8-10mm	Mã	T(mm)	Kg/m	Nẹp kính 12mm	Mã	T(mm)	Kg/m	Nẹp kính hộp 19-21mm	Mã	T(mm)	Kg/m
	JP-8314	1.1	0.279		JP-8327	1.1	0.264		JP-8315	1.1	0.249

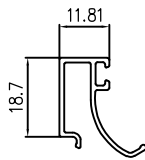

Nẹp kính rèm 33mm	Mã	T(mm)	Kg/m
	JP-15227	1.1	0.205

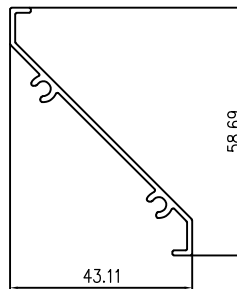
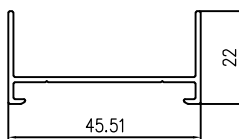

Khung bao lá sách	Mã	T(mm)	Kg/m	Lá sách	Mã	T(mm)	Kg/m
	JP-8323	1.2	0.301		JP-8324	1.2	0.333

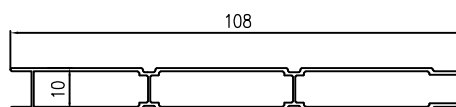
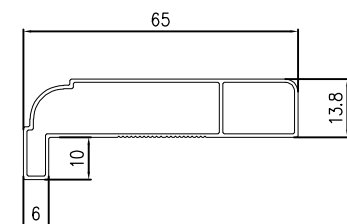

Nẹp chỉ tường	Mã	T(mm)	Kg/m	Pano	Mã	T(mm)	Kg/m
	JP-8317	0.8	0.489		JP-5520	0.8	0.554

# R83





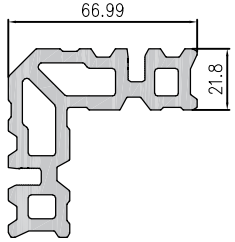
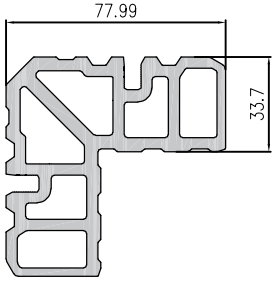
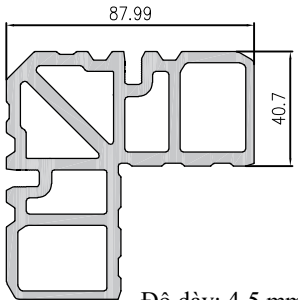
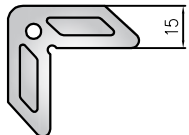





VẬT TƯ PHỤ

ĐỒNG BỘ HỆ R83

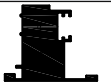
Công năng sử dụng	Mã ke	Quy cách (mm)	Hình ảnh
Ke khung bao đi, sổ, vách kính (khoảng lớn) hệ R83	K-BG2146	21.8 x 46	 <p>Độ dày: 4-5 mm</p>
Ke cánh sổ hệ R83			
Ke khung bao đi, sổ, vách kính (khoảng nhỏ) hệ R83			
Ke khung bao đảo chiều hệ R83			
Ke cánh sổ mở quay hất hệ R83	K-BG3346	33.7 x 46	 <p>Độ dày: 4-5 mm</p>
Ke cánh đi mở quay hệ R83	K-BG4045	40.7 x 45	 <p>Độ dày: 4-5 mm</p>
Ke tăng cứng inox hệ R58, R65, R65 plus, SFD80, R83, SD115	K-TC42154B	42 x 15	 <p>Độ dày: 1 mm</p>

# R83

## VẬT TƯ PHỤ | ĐỒNG BỘ HỆ R83

Tên vật tư	Mã gioăng	Hình ảnh
<b>GIOĂNG HATSU - PHỐT LÔNG</b>		
Gioăng khung 4 mm	MR-8301H2	
Gioăng kính 3 mm	MR-8302H1	
Gioăng đáy rãnh khung bao	MR-1504H1	
Lông nheo quét chân cánh 5 mm	MR-1565	
<b>NHỰA</b>		
Nhựa bịt 2 đầu đổ động hệ R83	DD-8301	
Nhựa bịt 2 đầu ốp chân cánh hệ R83 ( JP-8309 )	OC-8301	
Nhựa gắn ngưỡng nhôm hệ R83	NN-8301	
Nhựa bịt 2 đầu ốp ngưỡng nhôm hệ R83	ON-8301	
<b>DAO PHAY ĐỔ - DAO BẮM GÓC</b>		
Dao phay đổ chia ô vách kính + đổ tách khung	PT-8307	
Dao phay đổ chia ô cánh	PT-8308	
Dao bấm góc máy TNK dài 95 mm	PT-LBGTNK	
Dao bấm góc máy TQ dài 95 mm	PT-LBGTQ01	
Dao bấm góc máy TQ dài 120 mm	PT-LBGTQ02	